

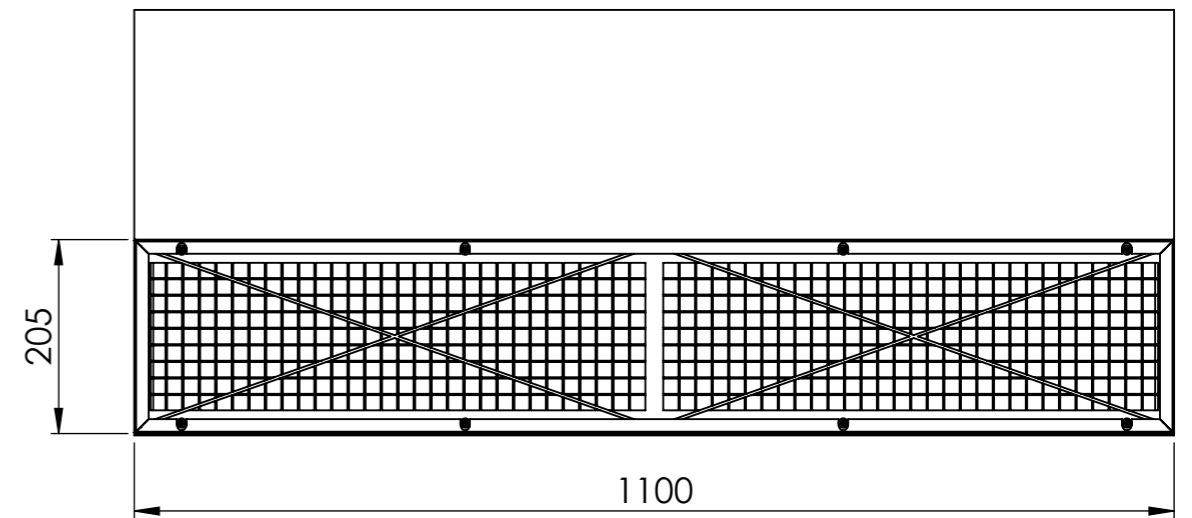

Queda prohibida toda reproducción de este documento, así como la utilización o transmisión de su contenido sin previa autorización.

**FILTRO COMPUESTO POR:
MARCO, MANTA Y 2 CLIP**

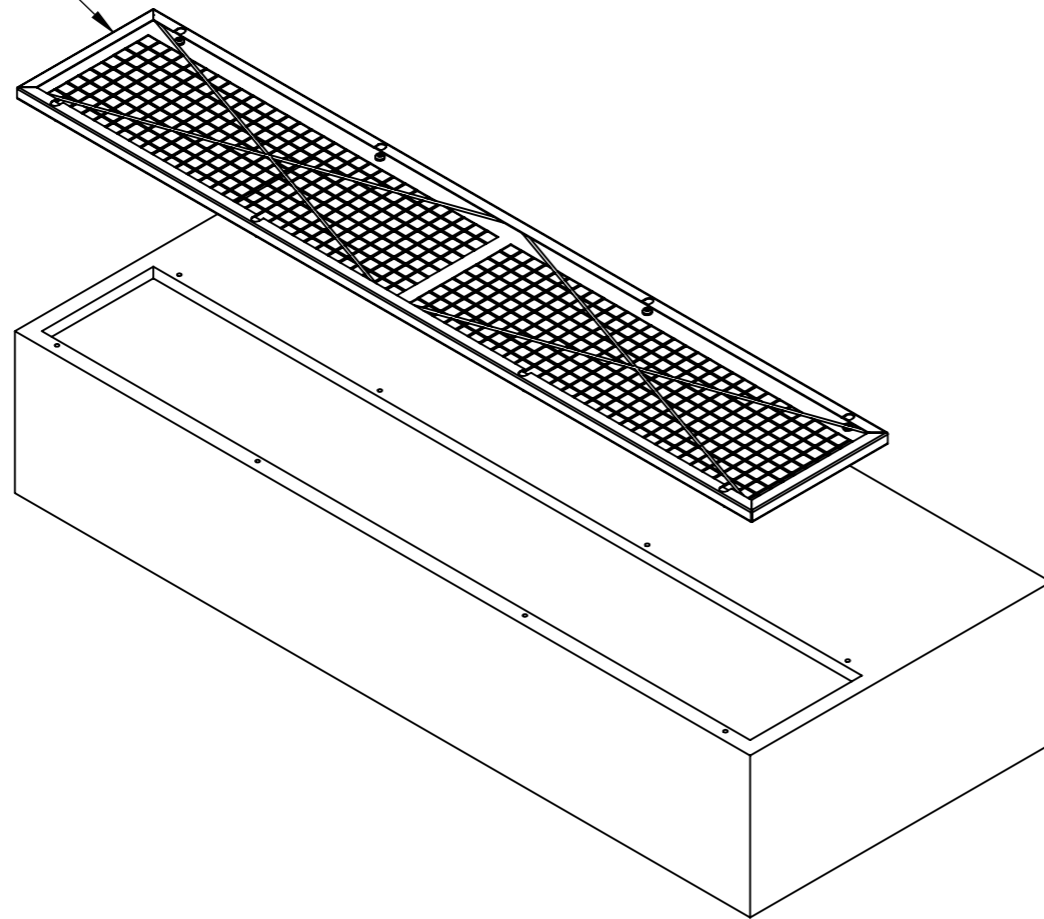

**MONTAJE VALIDO REF.:
RAS-M22U2DVGE, RAS-M24U2DVGE**

**FILTRO FIJADO EN ZONA SUPERIOR DE MAQUINA
ANCLADO MEDIANTE 8 TORNILLOS MONTADOS
RETIRANDO LA MANTA POR LA ZONA DE ATORNILLADO**

Material / Finished		Thickness(mm)	Weight (kg)	Tolerance	Units
			103	UNE-EN-22768	M.M.
Drawing by	Date	Revised by	Date	Drawing Number / Technical Reference	
J.Cambra	03/03/2017	M.A.Delgado	03/03/2017	/ 4000170	
		Description			
		ASSEMBLY FILTER			
Code		Revision	Scale		
6000002733		A	1:8		

ENGLISH

FILTER COMPOSED OF: FRAME, BLANKET, 2 CLIP AND 8 SCREWS

FILTER SET ON TOP OF THE MACHINE FIXED WITH 4 SCREWS. THE FILTER IS REMOVED BY SCREWING AREA.

ASSEMBLY VALID REF.: RAS-M22U2DVGE, RAS-M24U2DVGE

ITALIANO

FILTRO COMPOSTO DA: TELAIO, TELA, 2 CLIP E 8 VITI

FILTRO FISSATO NELLA ZONA SUPERIORE DELLA MACCHINA ANCORATO MEDIANTE 4 VITI MONTANDO TIRANDO LA TELA DALLA ZONA DELL'AVVTAMENTO.

MONTAGGIO VALIDO RIF.: RAS-M22U2DVGE, RAS-M24U2DVGE

FRAÇAISE

FILTRE FORMÉ PAR: CADRE, MEDIA FILTRANT, 2 CLIPS ET 8 VIS

LE FILTRE SERÁ FIXÉ AU MOYEN DE 4VIS DANS LA ZONE SUPÉRIEURE DE LA MACHINE EN RETIRANT LE MEDIA FILTRANT DANS LA ZONE DE VISSÉ.

MONTAGE VALIDE REF.: RAS-M22U2DVGE, RAS-M24U2DVGE

DEUTSCH

BESTANDTEILE DES FILTERS: RAHMEN, FILTERDECKE, 2 CLIPS UND 8 SCHRAUBEN

FILTER AUF DER OBERSEITE DER MASCHINE MIT 4 SCHRAUBEN FIXIERT. DIE FILTERDECKE AN DEN SCHRAUBSTELLEN ZURÜCKZIEHEN.

MONTAGEANLEITUNG GÜLTIG FÜR REF.: RAS-M22U2DVGE, RAS-M24U2DVGE

ESPAÑOL

FILTRO COMPUESTO POR: MARCO, MANTA, 2 CLIP Y 8 TORNILLOS

FILTRO FIJADO EN ZONA SUPERIOR DE MAQUINA ANCLADO MEDIANTE 4 TORNILLOS MONTADOS RETIRANDO LA MANTA POR LA ZONA DE ATORNILLADO.

MONTAJE VALIDO REF.: RAS-M22U2DVGE, RAS-M24U2DVGE

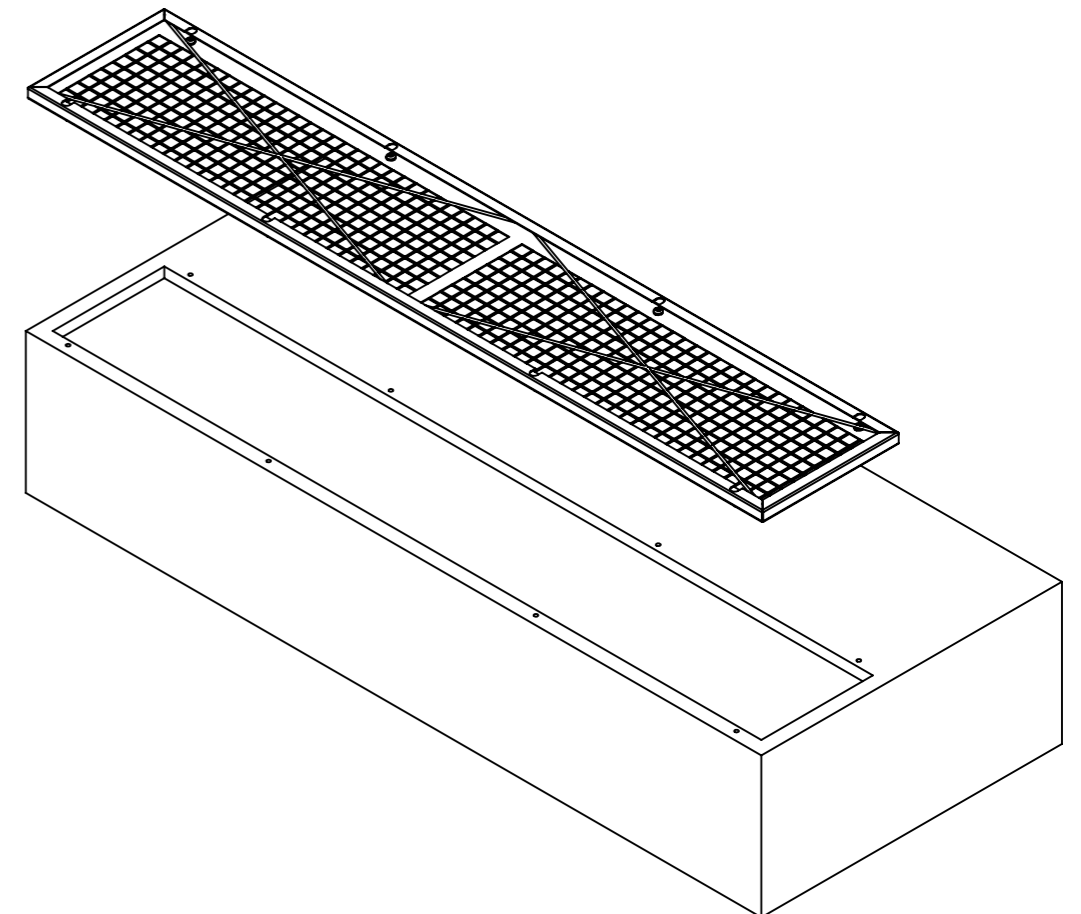

Queda prohibida toda reproducción de este documento, así como la utilización o transmisión de su contenido sin previa autorización.

Material / Finished		Thickness(mm)	Weight (kg)	Tolerance	Units
			103	UNE-EN-22768	M.M.
Drawing by	Date	Revised by	Date	Drawing Number / Technical Reference	
J.Cambra	03/03/2017	M.A.Delgado	03/03/2017	/ 4000170	
		Description			
		ASSEMBLY FILTER			
Code		Revision	Scale		
6000002733		A	1:8		