

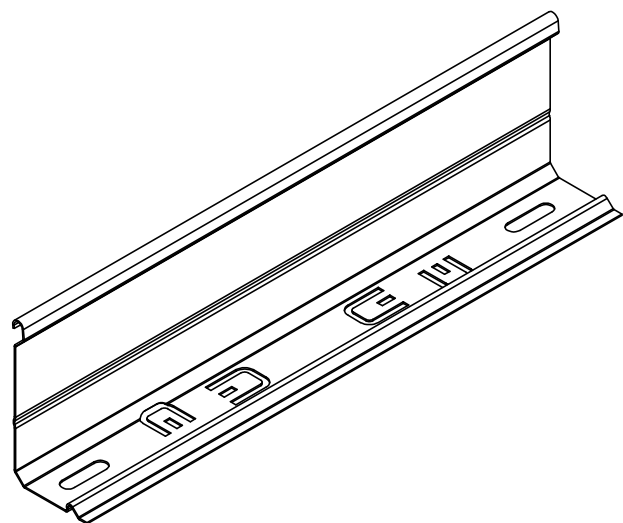

DÉTAIL A  
ECHELLE 1 : 2

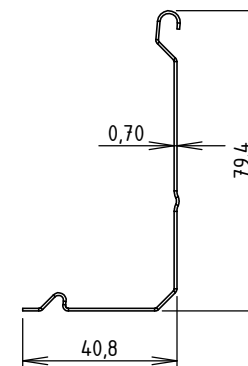

Poids net: 2.370 Kg  
 Colisage par 30 m  
 Matière: ACIER 0,70 DC01  
 Revêtement: GAC - NF EN ISO 1461

 	DESIGNATION:			
	SEPARATION BRN80-110 BFR110 GAC			
Usine de Liernais BP 1 21430 LIERNAIS TEL.: 03.80.90.51.00 FAX: 03.80.84.43.66	DESSINE PAR:	GUENOT F.	VERIFIE PAR:	LEGUY C.
	DATE:	21/10/2014	ECHELLE:	1:6
	N°:	MV65213X_06		

FORMAT  
A4 H

