

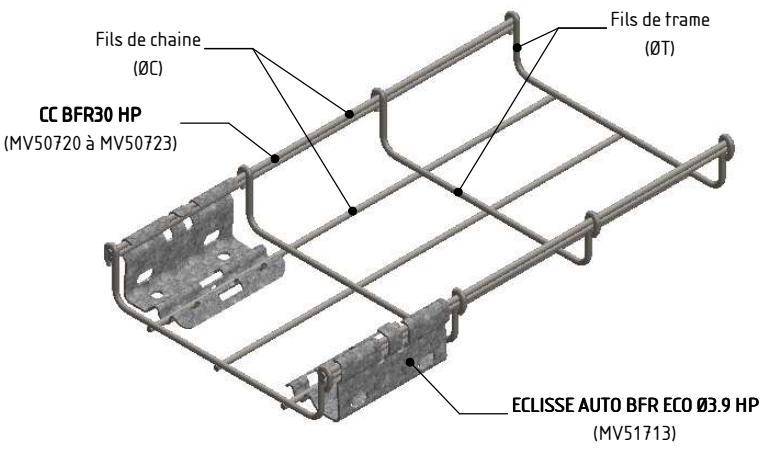

ECLISSE AUTO BFR ECO Ø3.9 HP		CC BFR30 HP				CC BFR30 PRE-ECLISSE HP					
CODE	POIDS NET (Kg)	CODE	L (mm)	H (mm)	POIDS NET (Kg)	CPS portée 1.5/2.0/2.5 m (daN/m)	CODE	L (mm)	POIDS NET (Kg)	COLISAGE	
										CC BFR30 (m)	ECLISSE (NR)
MV51713	0.073	MV50720	50	42.2	1.190	8/6/4	MV50770	50	1.263	30	10
		MV50721	100		1.589		MV50771	100	1.735		20
		MV50722	150		2.533	11/7.5/5	MV50772	150	2.679	18	12
		MV50723	200		2.932	15/10/7.5	MV50773	200	3.078	12	8

Chaque longueur de chemin de câbles est livrée avec 2 éclisses.
Sauf pour la largeur 50, livrée avec 1 seule éclisse (voir colisage)

ECLISSE AUTO BFR ECO Ø3.9 HP:
Matière: BANDE REFENDUE 1.25 S350GD + ZA255
Revêtement: ZA255 - NF EN 10346

CC BFR30 HP:
Matière: FIL Ø3.7 C9D CRAPAL 4 - NF EN 10016-2
Revêtement: ZA275 CLASSE A - NF EN 10244-2
CPS (Charge Pratique de Sécurité selon NF EN 61537)



 	DESIGNATION:				
	CC BFR30 PRE-ECLISSE HP				
Usine de Liernais BP 1 21430 LIERNAIS TEL.: 03.80.90.51.00 FAX: 03.80.84.43.66	DESSINE PAR:	BERGEROT D.	VERIFIE PAR:	LEGUY C.	FORMAT A4 H
	DATE:	16/09/2016	ECHELLE:	1:4	
	N°:	MV50770 à MV50773_02			