

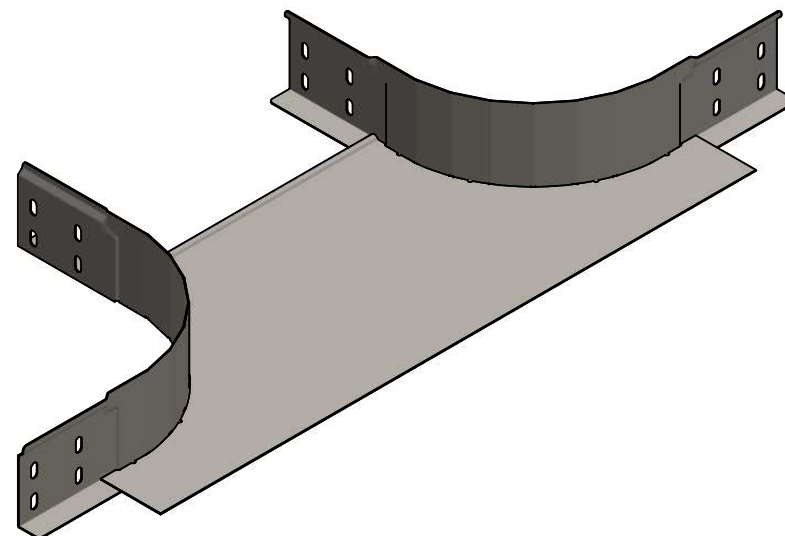

CODE	REF.	L (mm)	L1 (mm)	L2 (mm)	SURFACE (mm ²)	POIDS NET (Kg)	COLISAGE (NR)
MVG1420LL	305	850.8	303.8	341.4	420748	1.767	10
MVG1420LP	395	940.8	393.8	341.4	466200	1.960	8
MVG1420LU	515	1086.8	513.8	354.4	551833	2.321	8
MVG1420LX	605	1150.8	603.8	341.4	572255	2.408	6

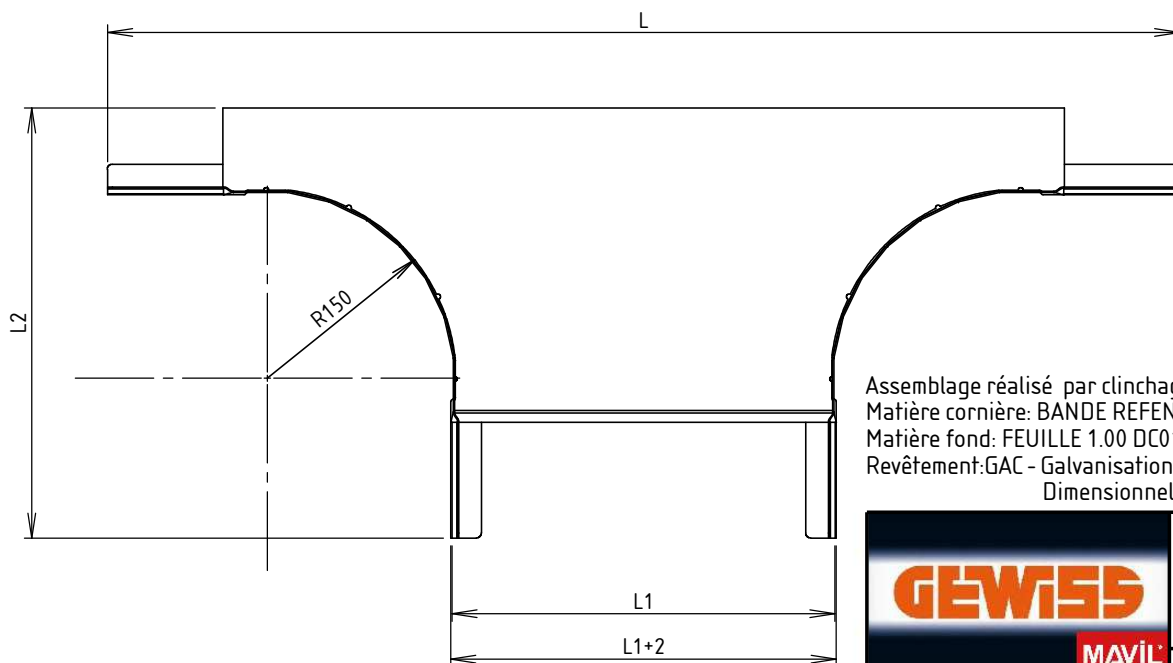
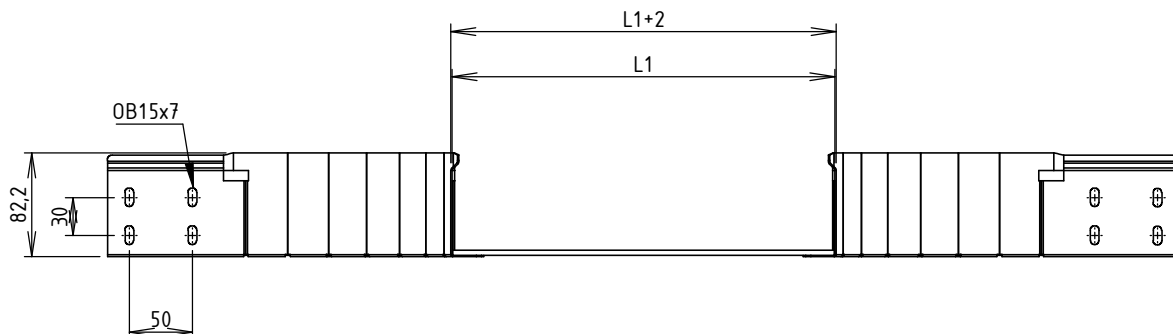

Assemblage réalisé par clinchage
 Matière cornière: BANDE REFENDUE 1,00 DC01 - NF EN 10130 / 10131
 Matière fond: FEUILLE 1.00 DC01 - NF EN 10130 / 10131
 Revêtement: GAC - Galvanisation à chaud par immersion selon NF EN 1461
 Dimensionnel garanti avant galvanisation

  Usine de Liernais BP 1 21430 LIERNAIS TEL.: 03.80.90.51.00 FAX: 03.80.84.43.66	DESIGNATION:		SORTIE LATERAL BRN80 NP R150 GAC		
	Propriété GEWISS France - Toute reproduction et utilisation tierce requièrent l'accord écrit de GEWISS France				
	DESSINE PAR:	BERGEROT D.	VERIFIE PAR:	LEGUY C.	FORMAT A4 H
	DATE:	13/05/2019	ECHELLE:	1:6	
N°:	MVG1420LL à MVG1420LX_01			