

Colisage: 25 pièces
 Poids net: 0.123 Kg
 Matière: FEUILLE 1.00 DX51D + Z275 - NF EN 10143/10346
 Revêtement: Z275 - NF EN 10346



DESIGNATION:

ECLISSE D'ANGLE UNIV BRN80 Z275

Propriété GEWISS France - Toute reproduction et utilisation tierce requièrent l'accord écrit de GEWISS France

Usine de Liernais
 BP 1
 21430 LIERNAIS
 TEL.: 03.80.90.51.00
 FAX: 03.80.84.43.66

DESSINE PAR:	BERGEROT D.	VERIFIE PAR:	LEGUY C.	FORMAT
DATE:	28/08/2023	ECHELLE:	1:1	A3 H
N°:	MVC3510LA_02			

REDUCTIONS: PLIAGE 30 mm

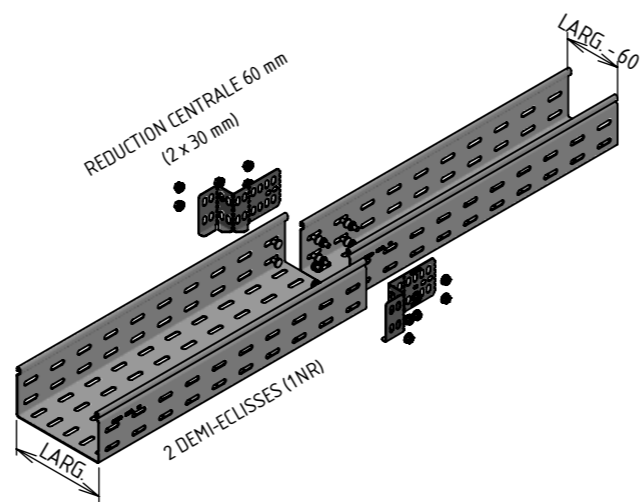
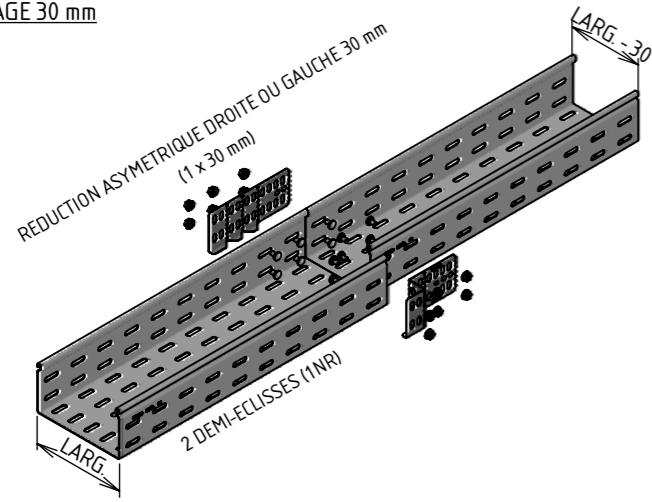

ECLISSE

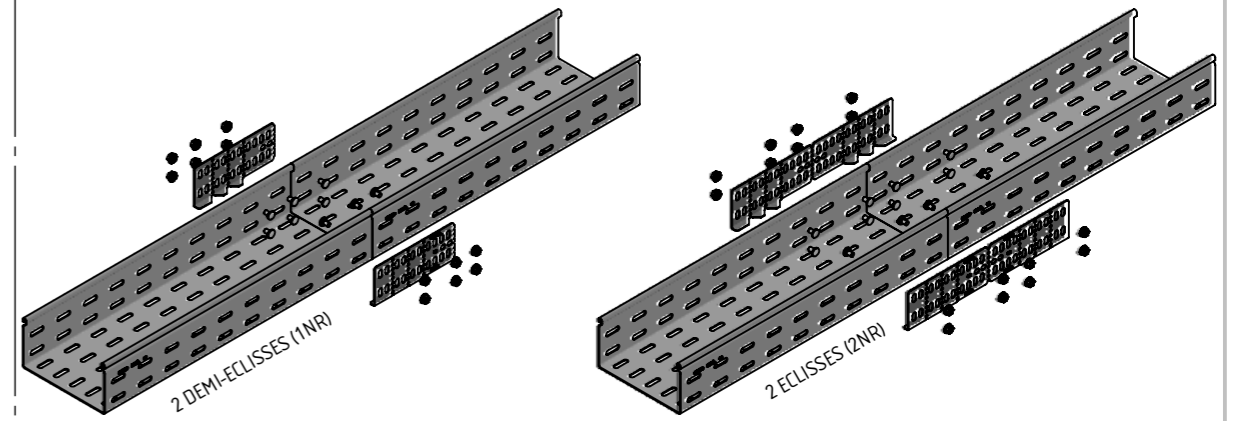

REDUCTIONS: PLIAGE 60 mm

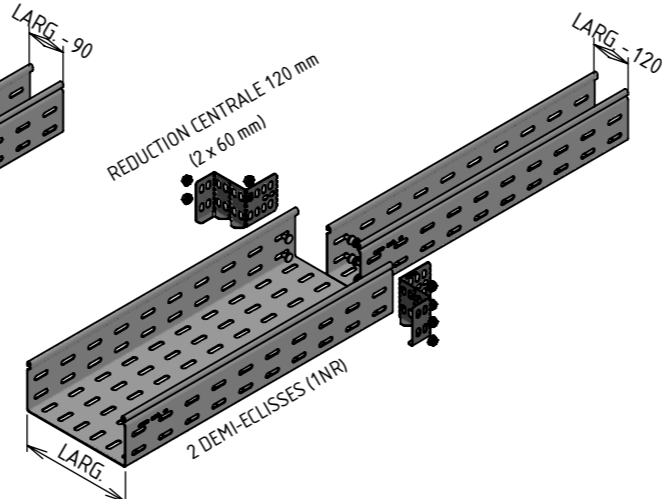
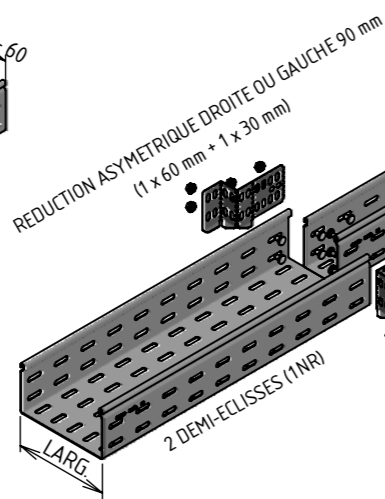
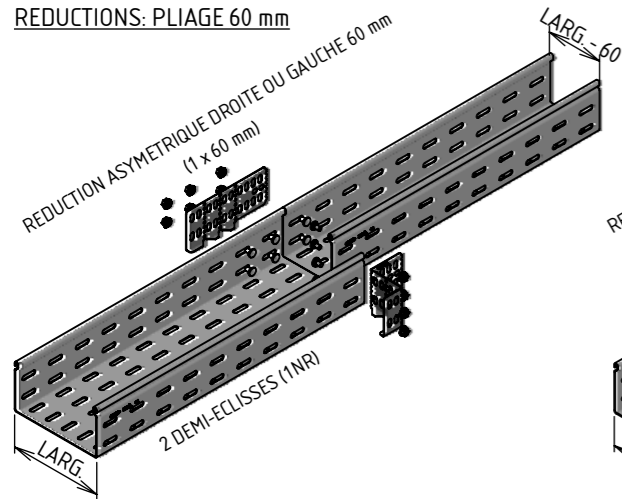

ECLISSE PLIABLE
PLAGE DE PLIAGE: 0° à 90°

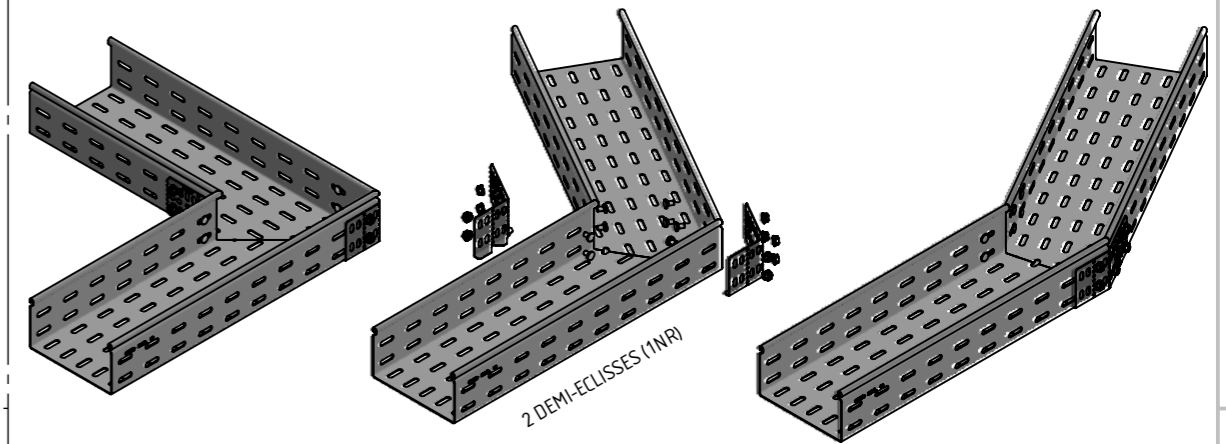

REDUCTIONS: PLIAGE 90 mm

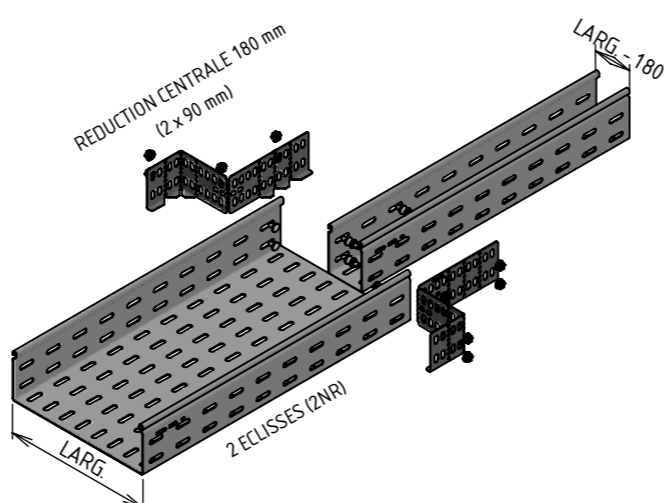
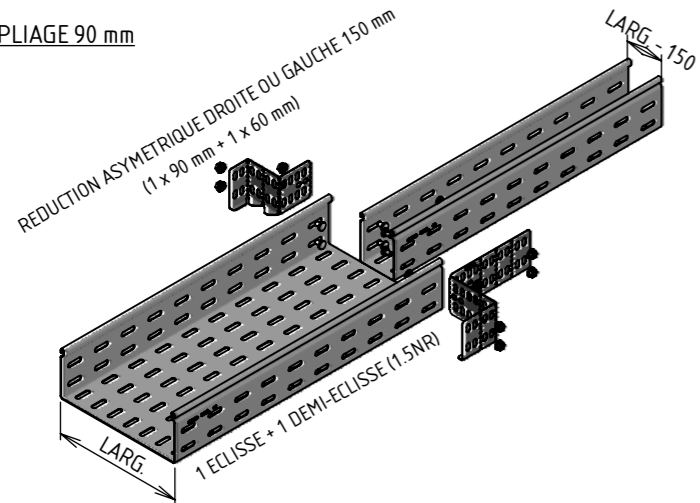

ECLISSE ARTICULEE

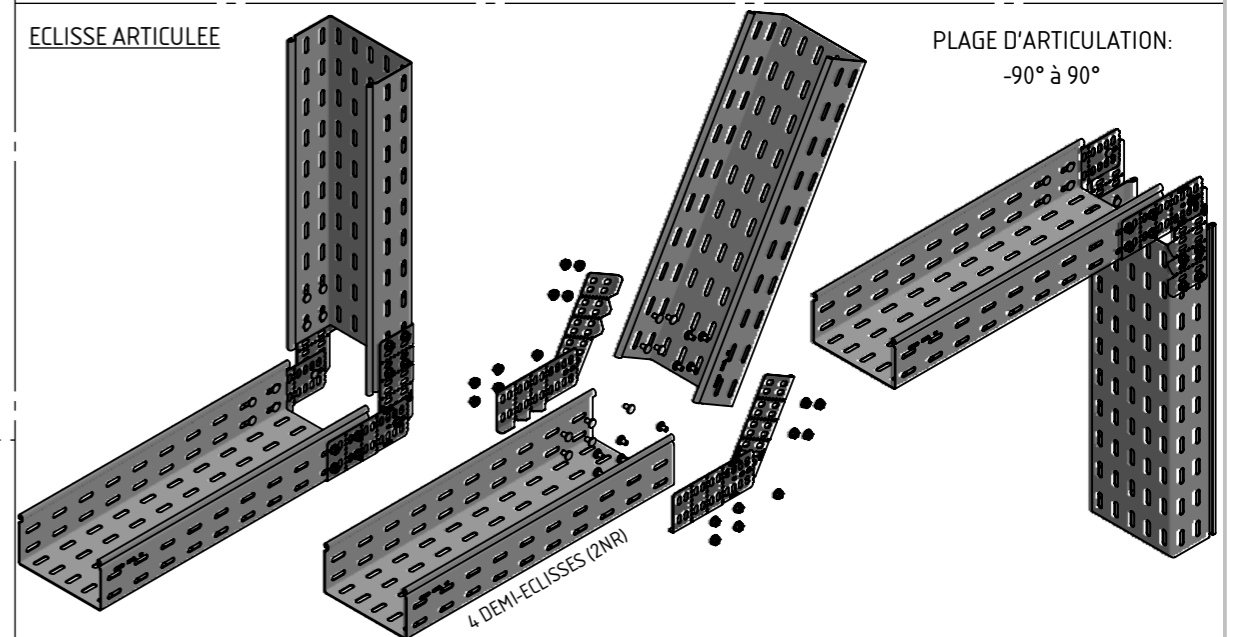

REDUCTIONS: PLIAGE 120 mm

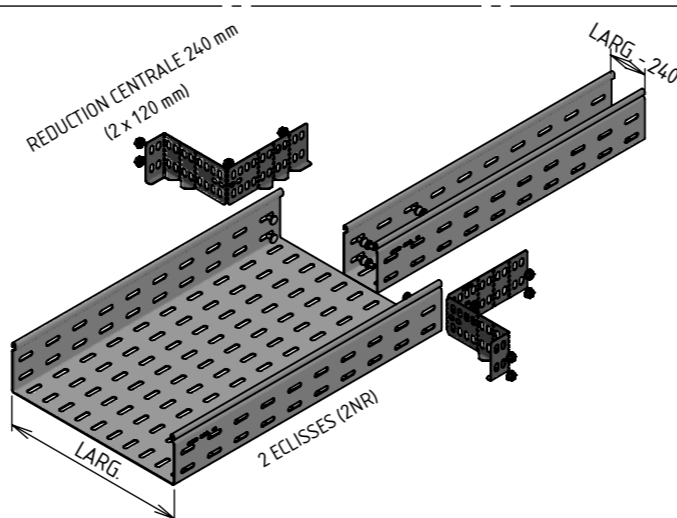
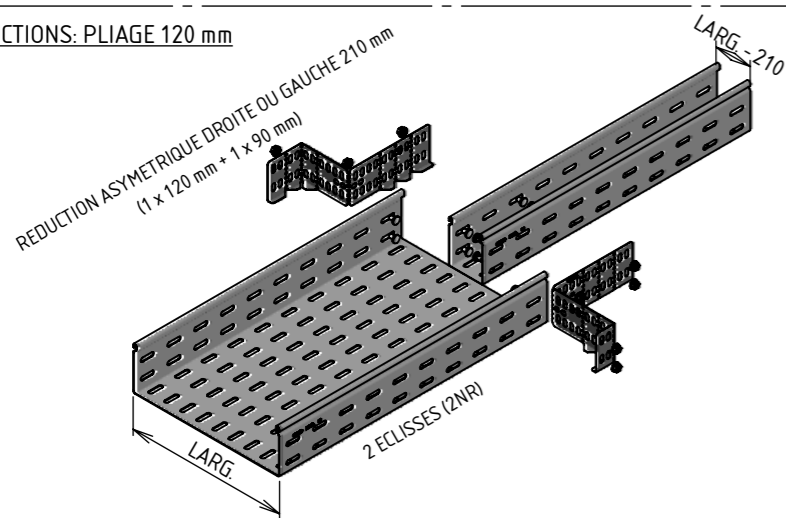

DESIGNATION:

ECLISSE D'ANGLE UNIV BRN80

Propriété GEWISS France - Toute reproduction et utilisation tierce requièrent l'accord écrit de GEWISS France

Usine de Liernais
BP 1
21430 LIERNAIS
TEL.: 03.80.90.51.00
FAX: 03.80.84.43.66

DESSINE PAR:	BERGEROT D.	VERIFIE PAR:	LEGUY C.	FORMAT
DATE:	28/08/2023	ECHELLE:	1:10	A3 H
N°:	MVC3510LA et MVC3520LA et MVC3570LA			