

Matière: FIL CLAIR Ø3.7 C9D CLASSE 1 - NF EN 16120-2
 Aptitude à la galvanisation: CLASSE 1 [Si(%) < 0.03 et Si(%) + 2.5 P(%) < 0.09]
 Revêtement: GAC - Galvanisation à chaud par immersion selon NF EN 1461
 Dimensionnel garanti avant galvanisation
 CPS: Charge pratique de sécurité - NF EN 61537

CODE	L (mm)	POIDS NET (Kg)	COLISAGE (m)	CPS portée 1.5/2.0/2.5m (daN/m)
MV50222	150	2.611	18	11/7.5/5
MV50223	200	3.022	12	15/10/7.5



Usine de Liernais
 BP 1
 21430 LIERNAIS
 TEL.: 03.80.90.51.00
 FAX: 03.80.84.43.66

DESIGNATION:		CC 150/200 BFR30 GAC	
Propriété GEWISS France - Toute reproduction et utilisation tierce requièrent l'accord écrit de GEWISS France			
DESSINE PAR:	BERGEROT D.	VERIFIE PAR:	LEGUY C.
DATE:	09/07/2020	ECHELLE:	1:4
N°:	MV50222 et MV50223_05		FORMAT A4 H



CODE	REF.	L (mm)	L1 (mm)	POIDS NET (Kg)	POIDS NET (Kg/m)	vx (mm)	vy (mm)	S (mm ²)	Ixx (mm ⁴)	Iyy (mm ⁴)	Ixx/vx (mm ³)	Iyy/vy (mm ³)	RAYON DE GIRATION R (mm)
MV50222	150 BFR30	150	162.8	2.611	0.870	20.696	81.4	75.265	19344.041	311295.526	934.67	3824.27	82.99
MV50223	200 BFR30	200	212.8	3.022	1.007	20.19	106.4	86.017	22543.222	577334.844	1116.55	5426.08	107.996

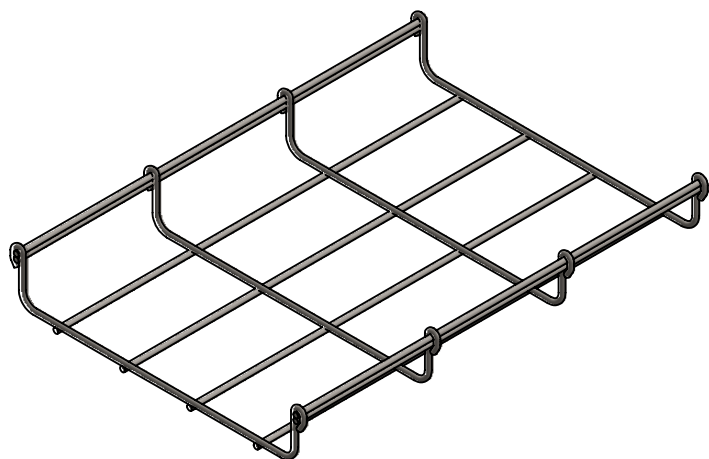
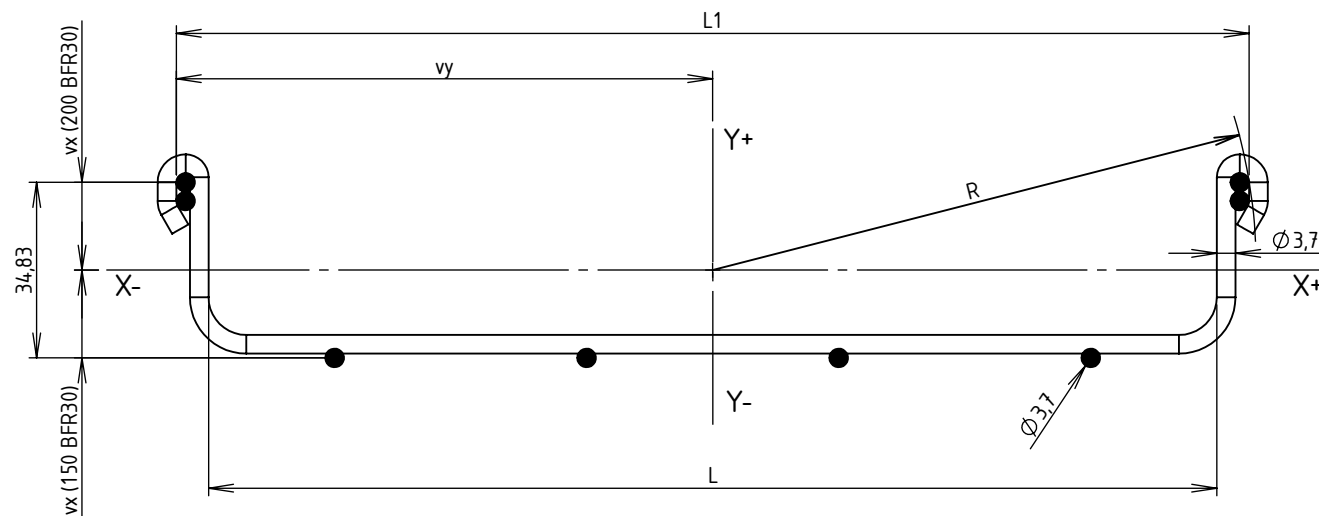

Matière: FIL CLAIR Ø3.7 C9D CLASSE 1 - NF EN 16120-2
 Aptitude à la galvanisation: CLASSE 1 [Si(%) < 0.03 et Si(%) + 2.5 P(%) < 0.09]
 Revêtement: GAC - Galvanisation à chaud par immersion selon NF EN 1461
 Dimensionnel garanti avant galvanisation



Usine de Liernais
 BP 1
 21430 LIERNAIS
 TEL.: 03.80.90.51.00
 FAX: 03.80.84.43.66

DESIGNATION: CC 150/200 BFR30 GAC INERTIES
 Propriété GEWISS France - Toute reproduction et utilisation tierce requièrent l'accord écrit de GEWISS France

DESSINE PAR:	BERGEROT D.	VERIFIE PAR:	LEGUY C.	FORMAT A4 H
DATE:	09/07/2020	ECHELLE:	1:1.5	
N°:	MV50222 et MV50223_05			

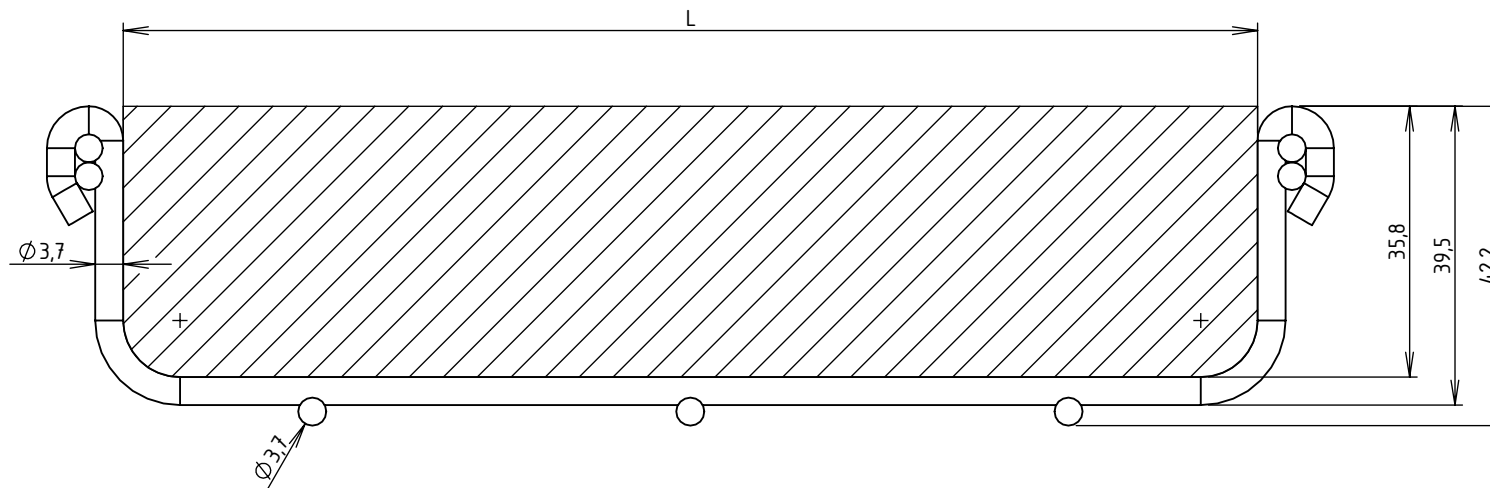

CODE	L (mm)	SECTION UTILE (mm ²)	CONTENANCE (Kg/m)	
			Communication (d = 0.15 Kg/cm ² /m)	Puissance (d = 0.25 Kg/cm ² /m)
MV50X22	150	5350	8.03	13.38
MV50X23	200	7142	10.71	17.86



Usine de Liernais
BP 1
21430 LIERNAIS
TEL.: 03.80.90.51.00
FAX: 03.80.84.43.66

DESIGNATION:

SECTIONS UTILES ET CONTENANCES BFR30
CC 150/200 BFR30

Propriété GEWISS France - Toute reproduction et utilisation tierce requièrent l'accord écrit de GEWISS France

DESSINE PAR:	BERGEROT D.	VERIFIE PAR:	LEGUY C.	FORMAT A4 H
DATE:	05/06/2024	ECHELLE:	1:1	
N°:	MV50X22 à MV50X23			