

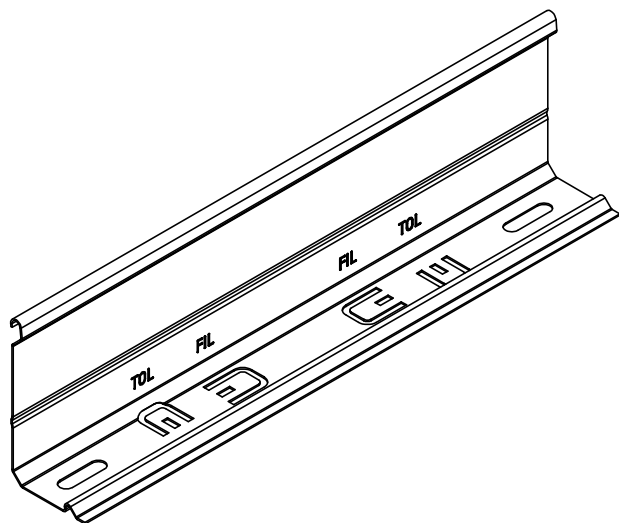

DÉTAIL A
ECHELLE 1 : 2

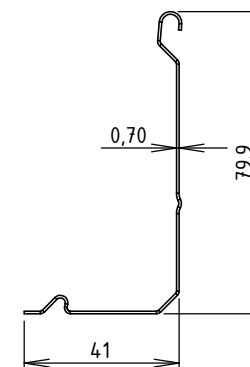

Poids (produit revêtu): 2.219 Kg
 Colisage par 30 m
 Matière: ACIER 0,70 S250 GD Z275 ou ACIER 0,70 S280 GD Z275
 Revêtement: Z275 - NF EN 10346

 	DESIGNATION:				
	SEPARATION BRN80-110 BFR110 Z275				
Usine de Liernais BP 1 21430 LIERNAIS TEL.: 03.80.90.51.00 FAX: 03.80.84.43.66	DESSINE PAR:	GUENOT F.	VERIFIE PAR:	LEGUY C.	FORMAT A4 H
	DATE:	12/06/2012	ECHELLE:	1:6	
	N°:	MV65113X_05			