



Colisage: par 10 pièces
 Poids net: 0.516 Kg
 Matière: FEUILLE 2,50 S235 JR
 Revêtement: GAC - NF EN ISO 1461
 Couple admissible: 12 daN.m - NF EN 61537

| | | | | |
|---|--|--------------------------|-----------------------|---|
|   | DESIGNATION: | | | TETE ORIENTABLE RAIL41-C40 GAC |
| | Usine de Liernais BP 1 21430 LIERNAIS TEL.: 03.80.90.51.00 FAX: 03.80.84.43.66 | DESSINE PAR: BERGEROT D. | VERIFIE PAR: LEGUY C. | |
| | DATE: 13/05/2015 | ECHELLE: 1:2 | | |
| | N°: | MV64255_01 | |  |

MONTAGE AVEC RAIL C40

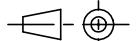
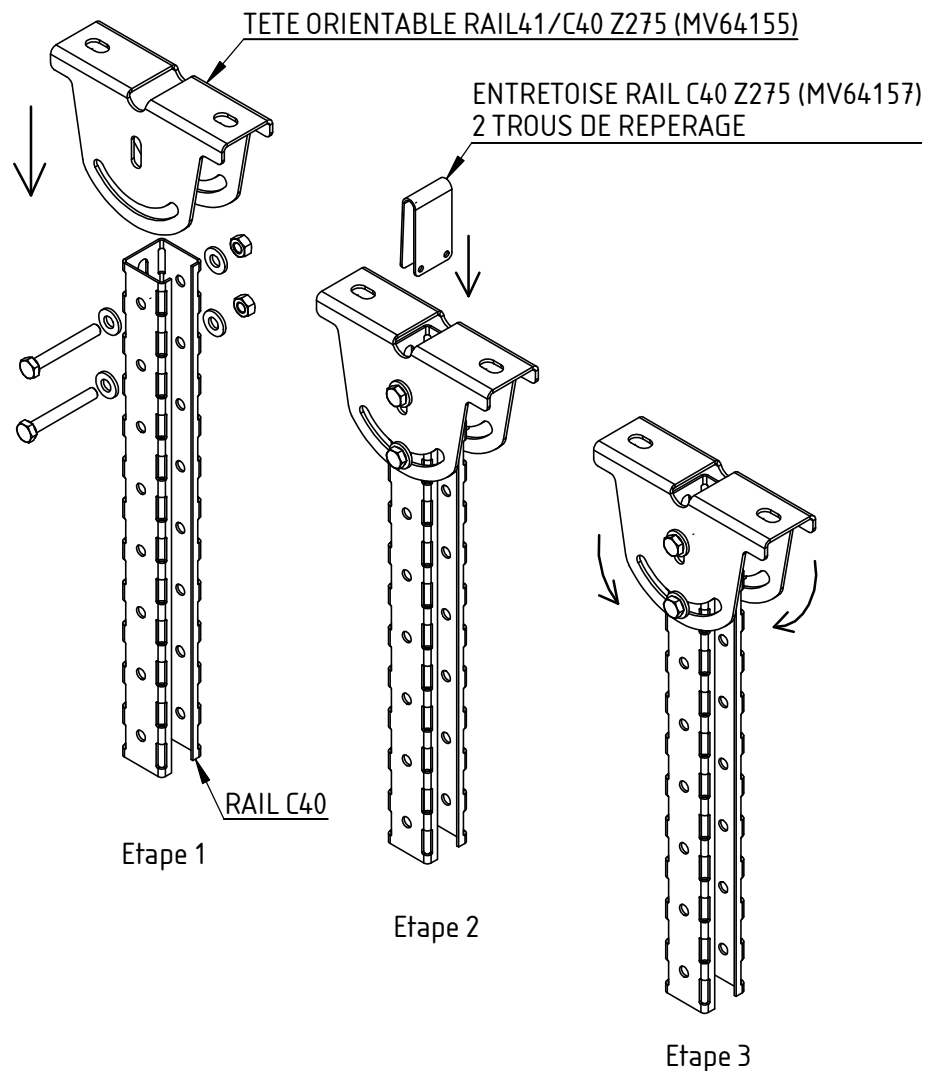

MONTAGE AVEC RAIL 41

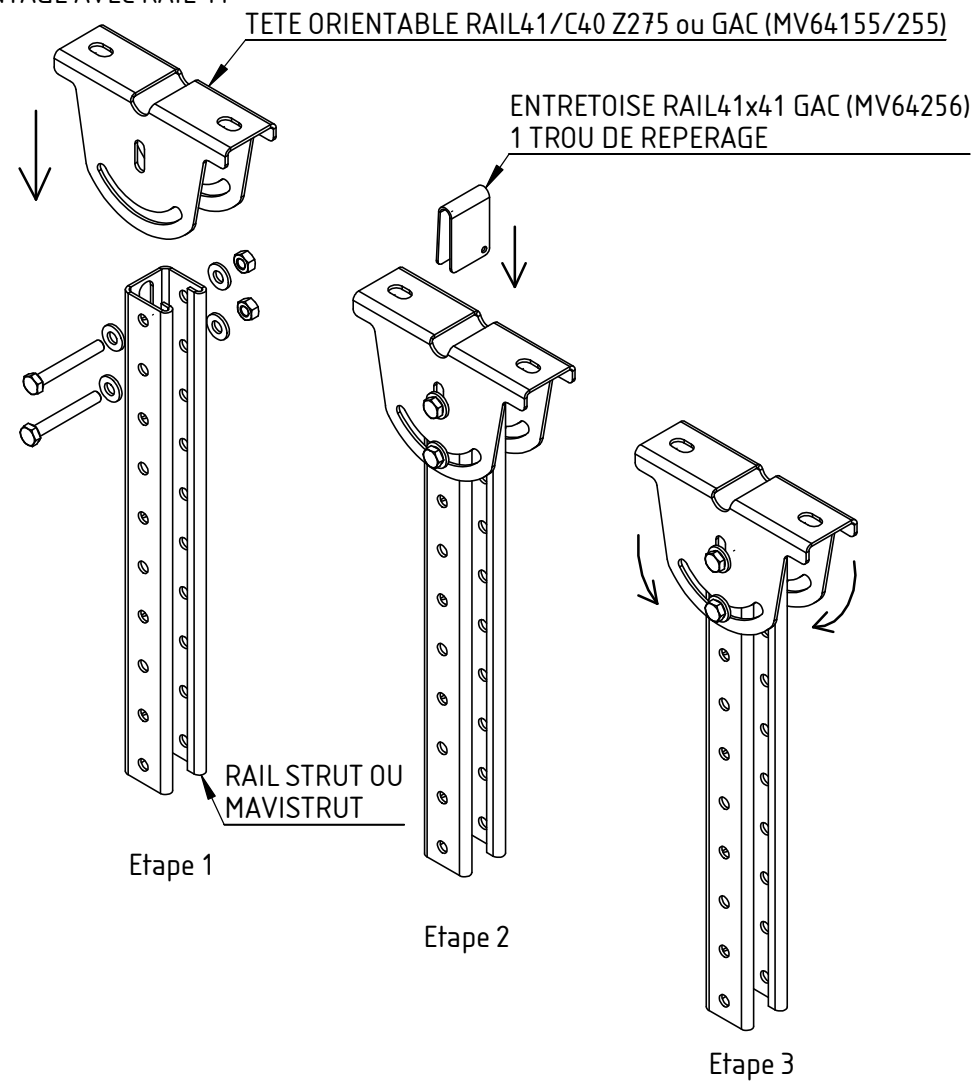

- 1: positionnement de la tête orientable sur le rail à l'aide des boulons HM8x60 + rondelles M 8 avec préserrage de ces derniers.
- 2: insertion l'entretoise adéquate dans le rail au travers de la tête.
- 3: mise en position et serrage des boulons au couple de 2.5 daN.m.

GEWISS

MAVIL

Usine de Liernais
BP 1
21430 LIERNAIS
TEL.: 03.80.90.51.00
FAX: 03.80.84.43.66

DESIGNATION:

MONTAGE TETE ORIENTABLE RAIL41-C40 Z275 ET GAC

| | | | | |
|--------------|--------------------|--------------|----------|----------------|
| DESSINE PAR: | GUENOT F. | VERIFIE PAR: | LEGUY C. | FORMAT A4 H |
| DATE: | 19/06/2012 | ECHELLE: | 1:5 | |
| N°: | MV64155 et MV64255 | | | |