

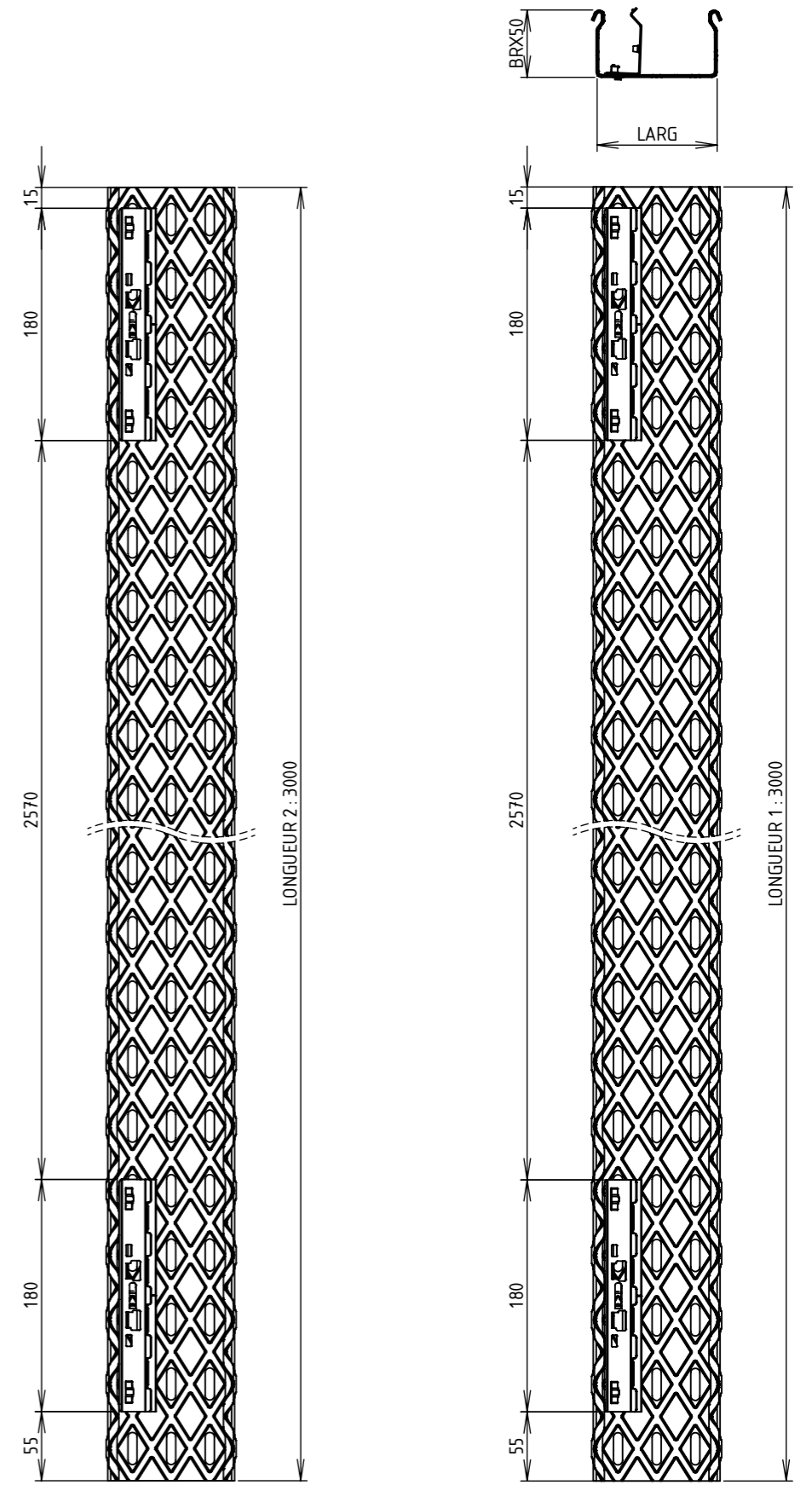

ARTICLE					COMPOSANTS ARTICLE							
CC BRX50 PRET-A-POSER HP					CC BRX50 HP			ECLISSE AUTO BRX50 HP				
CODE	DESIGNATION	REF.	LARG (mm)	POIDS NET (Kg)	CODE	Ep (mm)	POIDS NET (Kg)	CPS (daN/m)			CODE	POIDS NET (Kg)
								Portée (m)				
								1.5	2.0	2.5		
MVX0273GD	CC 95 BRX50 PRET-A-POSER HP	95	93.8	3.106	MVX40721	0.6	2.880	65	39	25	MVX0670GA	0.113
MVX0273GF	CC 155 BRX50 PRET-A-POSER HP	155	153.8	3.901	MVX40723	0.6	3.675	75.5	51.5	33		
MVX0273GH	CC 215 BRX50 PRET-A-POSER HP	215	213.8	4.696	MVX40725	0.6	4.470	75.5	51.5	33		
MVX0273GL	CC 305 BRX50 PRET-A-POSER HP	305	303.8	6.784	MVX40728	0.7	6.558	85	60	52		
MVX0273GP	CC 395 BRX50 PRET-A-POSER HP	395	393.8	10.335	MVX40731	0.9	10.109	100*	80*	58*		
MVX0273GU	CC 515 BRX50 PRET-A-POSER HP	515	513.8	12.680	MVX40735	0.9	12.454	108*	84.5*	64*		
MVX0273GX	CC 605 BRX50 PRET-A-POSER HP	605	603.8	14.439	MVX40737	0.9	14.213	108*	84.5*	64*		

*: Valeur de CPS indiquée avec installation d'un couvre-joint

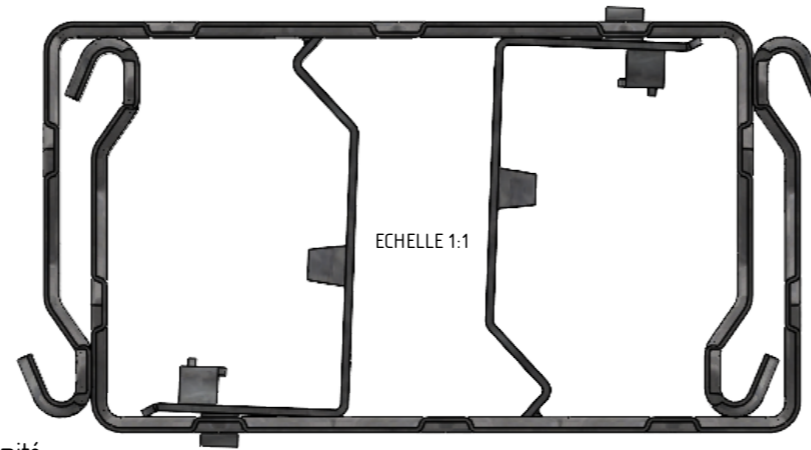
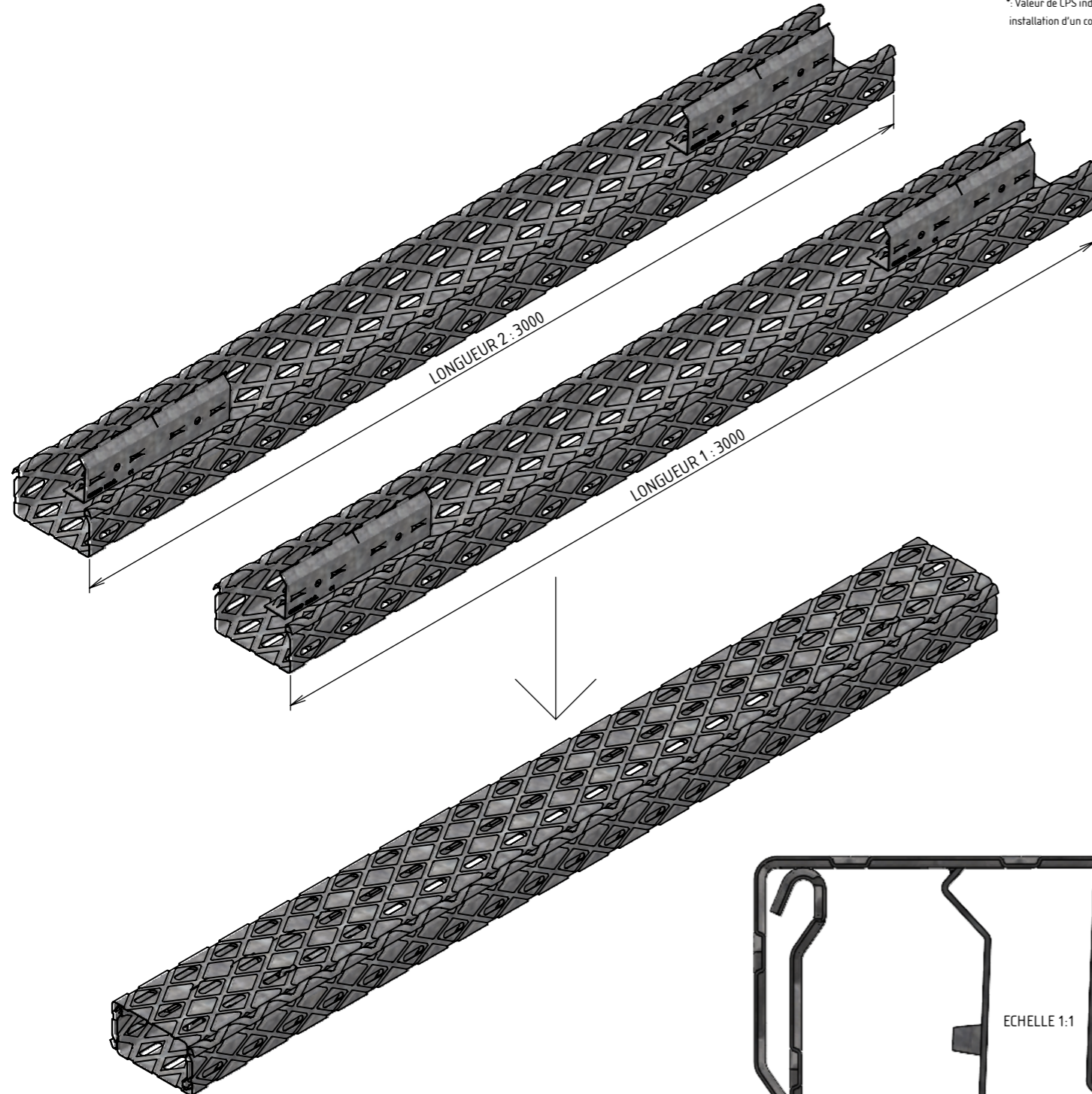

Matière cc: BOBINE DX51D + ZM250 - NF EN 10143/10346
 Matière éclisse: BANDE REFENDUE 1.00 DX51D + ZM250 - NF EN 10143/10346
 Revêtement: ZM250 - NF EN 10346
 Chaque longueur de chemin de câbles est livrée avec 2 éclisses, pré-assemblées, une à chaque extrémité



Usine de Liernais
 BP 1
 21430 LIERNAIS
 TEL.: 03.80.90.51.00
 FAX: 03.80.84.43.66

DESIGNATION: CC 95 à 605 BRX50 PRET-A-POSER HP

Propriété GEWISS France - Toute reproduction et utilisation tierce requièrent l'accord écrit de GEWISS France

DESSINE PAR: BERGEROT D.	VERIFIE PAR: LEGUY C.	FORMAT: A3 H
DATE: 28/02/2023	ECHELLE: 1:5	
N°: MVX0273GD à MVX0273GX		