

Matière : BANDE REFENDUE S350GD + ZM250 - NF EN 10143/10346
 Revêtement : ZM250 - NF EN 10346
 CPS : Charge Pratique de Sécurité - NF EN 61537



Usine de Liernais
 BP 1
 21430 LIERNAIS
 TEL.: 03.80.90.51.00
 FAX: 03.80.84.43.66

DESIGNATION:

CONSOLE UNIVERSELLE EN C HP
 CSUC

Propriété GEWISS France - Toute reproduction et utilisation tierce requièrent l'accord écrit de GEWISS France

DESSINE PAR: NOUAILLES-LADERACH C.	VERIFIE PAR: LEGUY C.	FORMAT A4 H
DATE: 17/12/2025	ECHELLE: 1:3	
N°:	MV62750 à MV62785_01	

CODE	REF.	H (mm)	H1 (mm)	H2 (mm)	L (mm)	e (mm)	A (mm)	B (mm)	C (mm)	D (mm)	POIDS NET (Kg)	COLISAGE (Pièces)	CPS (daN/cons)
MV62750	H150xL100	147.9	107.3	147.3	148.6	1.50	33	36.7	29.4	35	0,470	20	127
MV62751	H150xL150	147.9	107.3	147.3	198.6	1.50	33	36.7	29.4	35	0,521	16	94
MV62752	H150xL200	147.9	107.3	147.3	248.6	1.50	33	36.7	29.4	35	0,572	14	74.5
MV62753	H150xL250	149.2	108.1	148.1	299.1	1.75	33.5	37.2	29.9	35	0,723	12	
MV62754	H150xL300	149.2	108.1	148.1	349.1	1.75	33.5	37.2	29.9	35	0,782	10	61
MV62755	H150xL400	149.2	108.1	148.1	449.1	1.75	33.5	37.2	29.9	35	0,899	14	47
MV62756	H200xL100	197.9	107.3	147.3	148.6	1.50	33	36.7	29.4	85	0,527	20	127
MV62757	H200xL150	197.9	107.3	147.3	198.6	1.50	33	36.7	29.4	85	0,578	16	94
MV62758	H200xL200	197.9	107.3	147.3	248.6	1.50	33	36.7	29.4	85	0,629	14	74.5
MV62759	H200xL250	199.2	108.1	148.1	299.1	1.75	33.5	37.2	29.9	85	0,790	12	
MV62760	H200xL300	199.2	108.1	148.1	349.1	1.75	33.5	37.2	29.9	85	0,849	10	61
MV62761	H200xL400	199.2	108.1	148.1	449.1	1.75	33.5	37.2	29.9	85	0,966	14	47
MV62762	H230xL100	227.9	107.3	147.3	148.6	1.50	33	36.7	29.4	115	0,563	20	127
MV62763	H230xL150	227.9	107.3	147.3	198.6	1.50	33	36.7	29.4	115	0,614	16	94
MV62764	H230xL200	227.9	107.3	147.3	248.6	1.50	33	36.7	29.4	115	0,665	14	74.5
MV62765	H230xL250	229.2	108.1	148.1	299.1	1.75	33.5	37.2	29.9	115	0,831	12	
MV62766	H230xL300	229.2	108.1	148.1	349.1	1.75	33.5	37.2	29.9	115	0,890	10	61
MV62767	H230xL400	229.2	108.1	148.1	449.1	1.75	33.5	37.2	29.9	115	1,007	16	47
MV62768	H300xL100	297.9	107.3	147.3	148.6	1.50	33	36.7	29.4	185	0,641	24	127
MV62769	H300xL150	297.9	107.3	147.3	198.6	1.50	33	36.7	29.4	185	0,692	16	94
MV62770	H300xL200	297.9	107.3	147.3	248.6	1.50	33	36.7	29.4	185	0,743	16	74.5
MV62771	H300xL250	299.2	108.1	148.1	299.1	1.75	33.5	37.2	29.9	185	0,922	8	
MV62772	H300xL300	299.2	108.1	148.1	349.1	1.75	33.5	37.2	29.9	185	0,981	8	61
MV62773	H300xL400	299.2	108.1	148.1	449.1	1.75	33.5	37.2	29.9	185	1,098	8	47
MV62774	H350xL100	347.9	107.3	147.3	148.6	1.50	33	36.7	29.4	235	0,698	16	127
MV62775	H350xL150	347.9	107.3	147.3	198.6	1.50	33	36.7	29.4	235	0,749	8	94
MV62776	H350xL200	347.9	107.3	147.3	248.6	1.50	33	36.7	29.4	235	0,800	8	74.5
MV62777	H350xL250	349.2	108.1	148.1	299.1	1.75	33.5	37.2	29.9	235	0,989	8	
MV62778	H350xL300	349.2	108.1	148.1	349.1	1.75	33.5	37.2	29.9	235	1,048	8	61
MV62779	H350xL400	349.2	108.1	148.1	449.1	1.75	33.5	37.2	29.9	235	1,165	8	47
MV62780	H400xL100	397.9	107.3	147.3	148.6	1.50	33	36.7	29.4	285	0,755	16	127
MV62781	H400xL150	397.9	107.3	147.3	198.6	1.50	33	36.7	29.4	285	0,806	8	94
MV62782	H400xL200	397.9	107.3	147.3	248.6	1.50	33	36.7	29.4	285	0,857	8	74.5
MV62783	H400xL250	399.2	108.1	148.1	299.1	1.75	33.5	37.2	29.9	285	1,055	8	
MV62784	H400xL300	399.2	108.1	148.1	349.1	1.75	33.5	37.2	29.9	285	1,114	8	61
MV62785	H400xL400	399.2	108.1	148.1	449.1	1.75	33.5	37.2	29.9	285	1,231	20	47



Usine de Liernais
BP 1
21430 LIERNAIS
TEL.: 03.80.90.51.00
FAX: 03.80.84.43.66

DESIGNATION:

CONSOLE UNIVERSELLE EN C HP
CSUC

Propriété GEWISS France - Toute reproduction et utilisation tierce requièrent l'accord écrit de GEWISS France

DESSINE PAR: NOUAILLES-LADERACH C.

VERIFIE PAR:

LEGUY C.

FORMAT

DATE:

13/11/2020

ECHELLE:

1:4

A4 V

N°:

MV62750 à MV62785_01

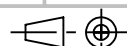

FIXATION AU MUR

CODE	DESIGNATION	QTE
MV66278	RONDELLE PLATE M 10 GEOMET	1 NR / CONS

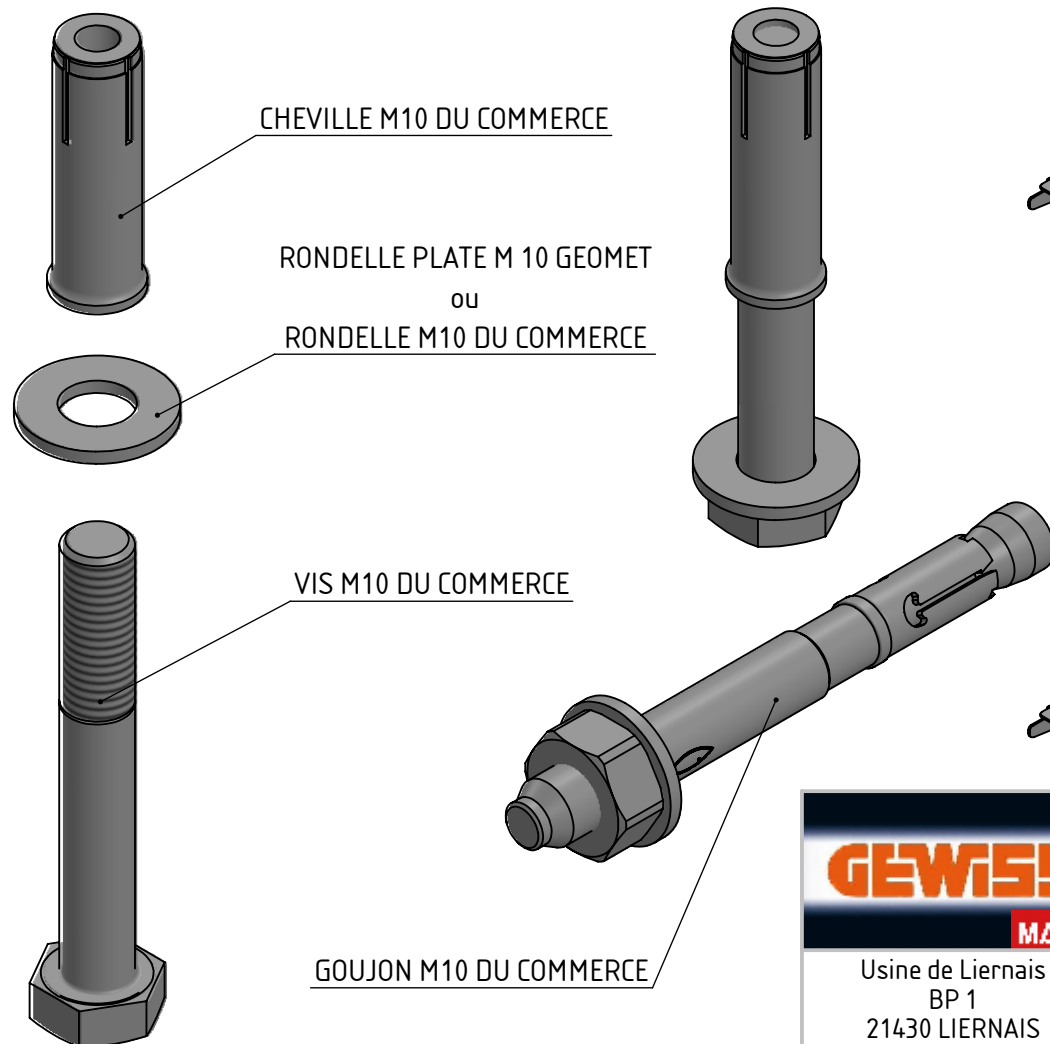

CHEVILLE M10 DU COMMERCE

RONDELLE PLATE M 10 GEOMET
ou
RONDELLE M10 DU COMMERCE

VIS M10 DU COMMERCE

GOUJON M10 DU COMMERCE

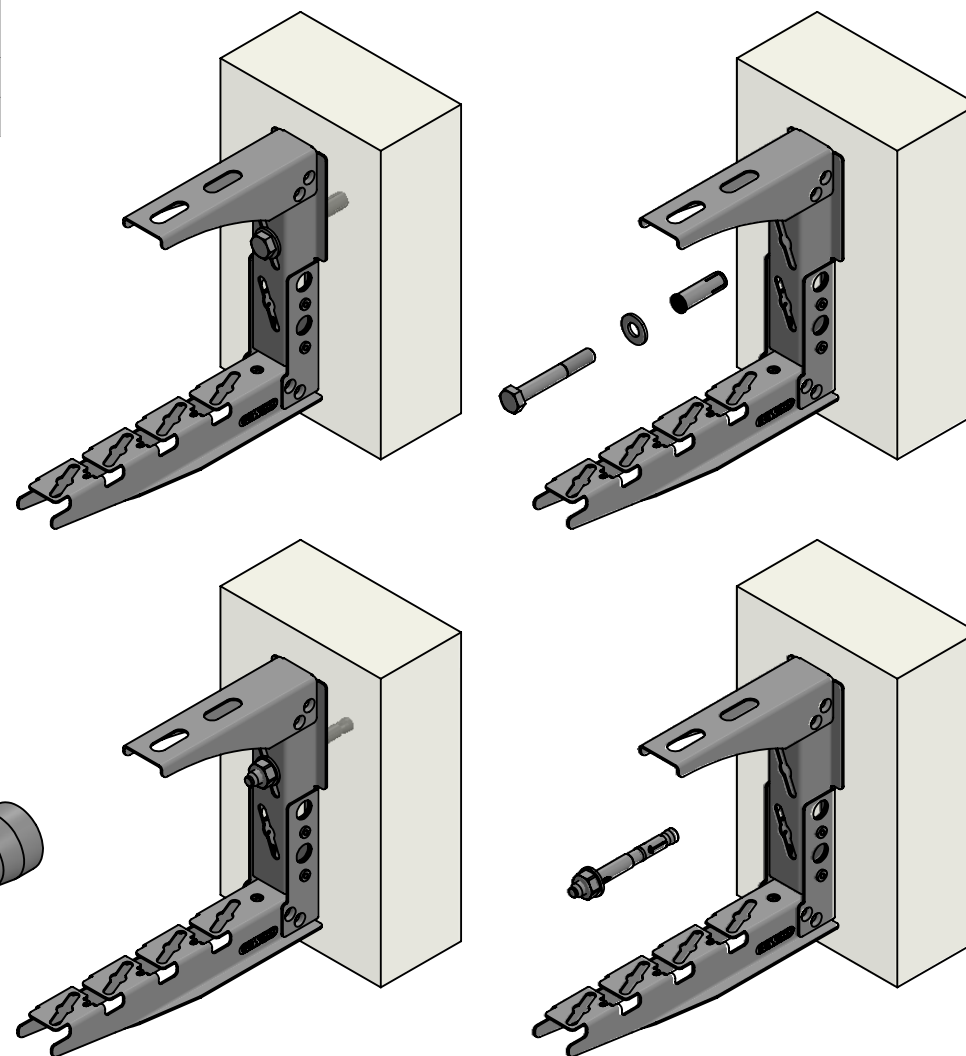

Usine de Liernais
BP 1
21430 LIERNAIS
TEL.: 03.80.90.51.00
FAX: 03.80.84.43.66

DESIGNATION:

FIXATION AU MUR HP

Propriété GEWISS France - Toute reproduction et utilisation tierce requièrent l'accord écrit de GEWISS France

DESSINE PAR: NOUAILLES-LADERACH C.	VERIFIE PAR: LEGUY C.	FORMAT A4 H
DATE: 16/12/2025	ECHELLE: 1:5	
N°:	MV62750 à MV62785_01	

FIXATION AU PLAFOND

CODE	DESIGNATION	QTE
MV66278	RONDELLE PLATE M 10 GEOMET	1 NR / CONS

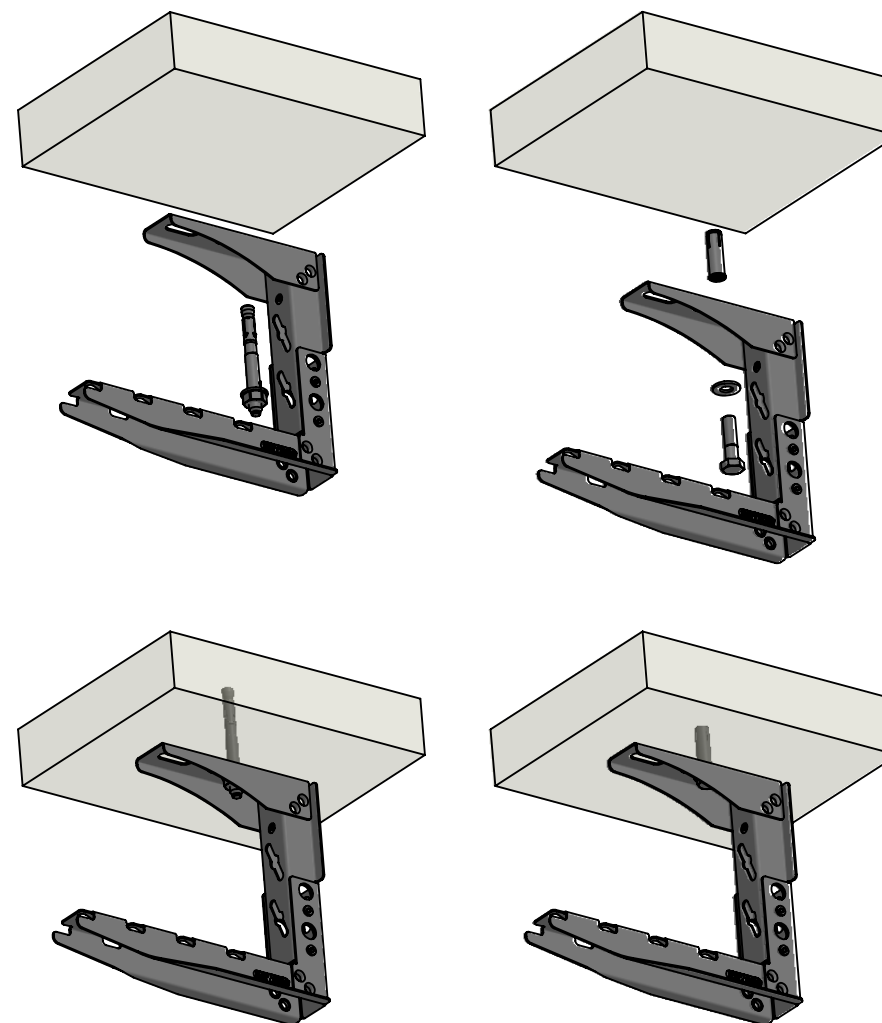
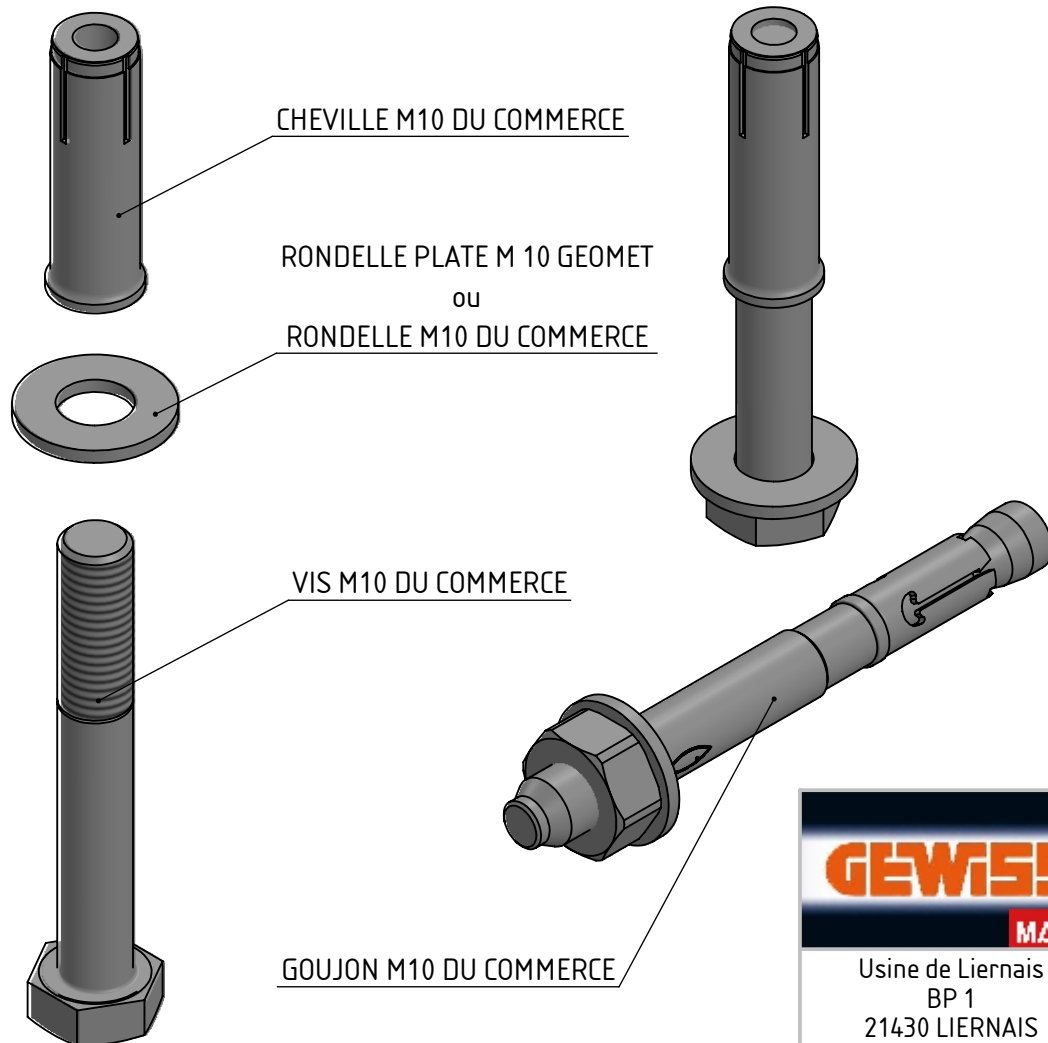

Usine de Liernais
BP 1
21430 LIERNAIS
TEL.: 03.80.90.51.00
FAX: 03.80.84.43.66

DESIGNATION: **FIXATION AU PLAFOND HP**
 Propriété GEWISS France - Toute reproduction et utilisation tierce requièrent l'accord écrit de GEWISS France

DESSINE PAR: NOUAILLES-LADERACH C.	VERIFIE PAR: LEGUY C.	FORMAT A4 H
DATE: 16/12/2025	ECHELLE: 1:6	
N°: MV62750 à MV62785_01		

VERROUILLAGE CHEMIN DE CABLES BFR SUR CONSOLE UNIVERSELLE MURALE

MONTAGE CHEMIN DE CABLES BFR SUR CONSOLE UNIVERSELLE MURALE

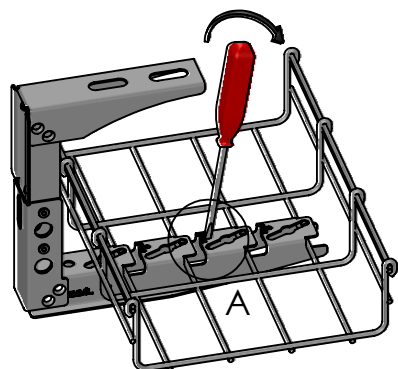

1) Introduire un tournevis dans la perfo des languettes de verrouillage

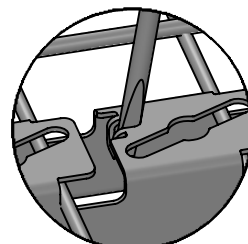

DÉTAIL A
ECHELLE 1 : 2

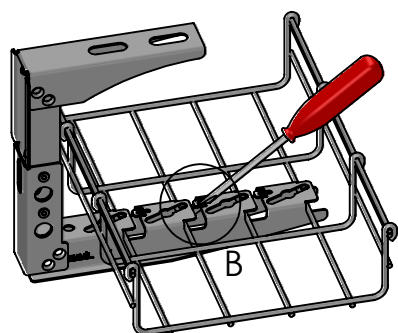

2) Faire pivoter le tournevis de façon à relever les languettes de verrouillage

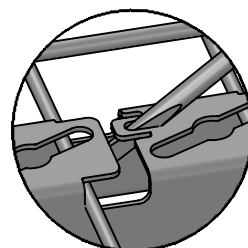

DÉTAIL B
ECHELLE 1 : 2

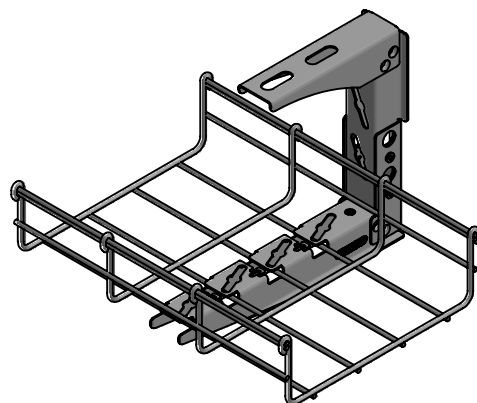

3) Le chemin de câbles est verrouillé sur la console

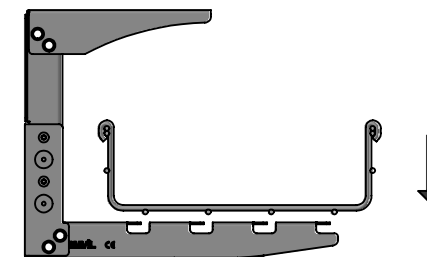

1) Introduire le chemin de câbles dans les encoches de la console

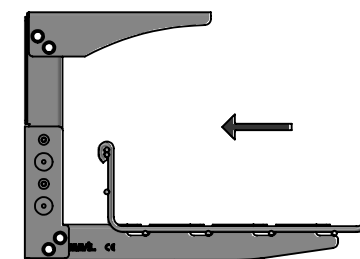

2) Faire coulisser le chemin de câbles dans les encoches de la console

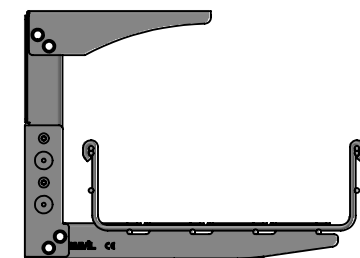

3) Le chemin de câbles est installé, sans être verrouillé



Usine de Liernais
BP 1
21430 LIERNAIS
TEL.: 03.80.90.51.00
FAX: 03.80.84.43.66

DESIGNATION:

BFR

Propriété GEWISS France - Toute reproduction et utilisation tierce requièrent l'accord écrit de GEWISS France

DESSINE PAR: NOUAILLES-LADERACH C.

VERIFIE PAR:

LEGUY C.

FORMAT

DATE:

15/12/2025

ECHELLE:

1:6

A4 H

N°:

MV62750 à MV62785_01

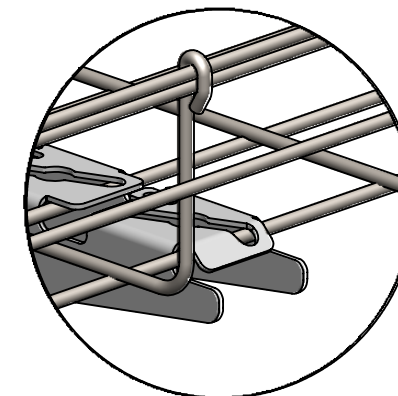
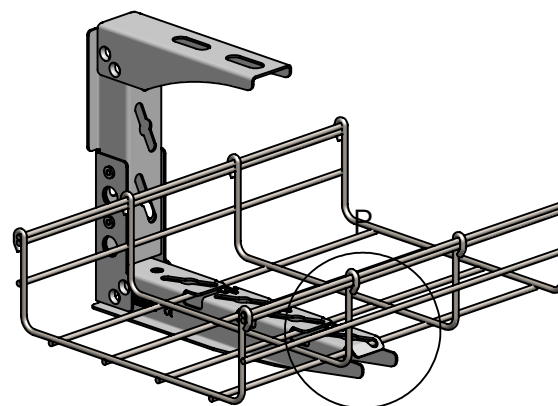
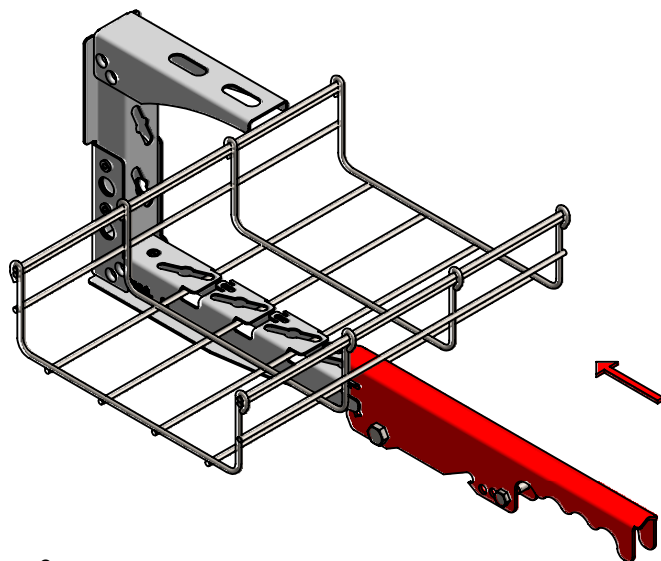

Etape 1

DÉTAIL P
ECHELLE 1 : 2

Etape 2

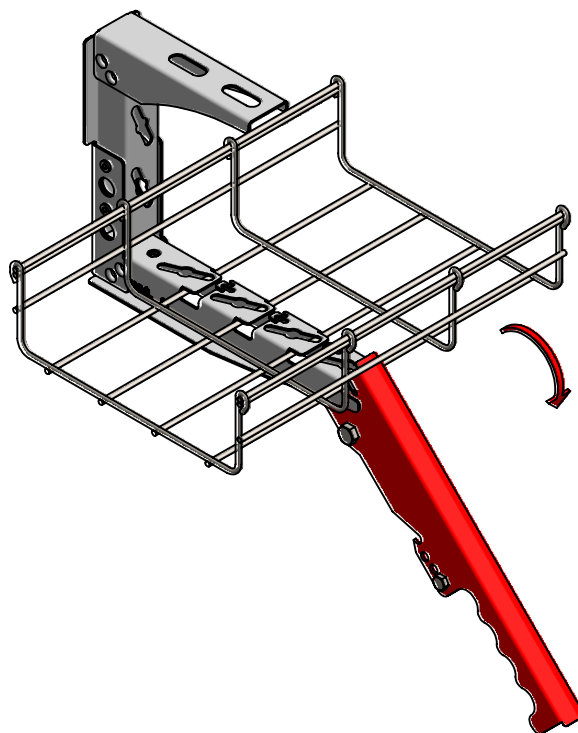

Etape 1 : insérer la clé en bout de console universelle (MV60x80 à MV60x85 et MV60x90 à MV60x95) de manière à pincer le fil et la console dans l'encoche prévue à cet effet.

Etape 2 : exercer une pression vers le bas sur la clé tout en maintenant la console en place pour déformer l'extrémité de la console >>> Le chemin de câbles est verrouillé.

Cette fonction permet de réaliser une déformation permanente de l'extrémité de la console afin de verrouiller totalement le chemin de câbles sur cette dernière.



Usine de Liernais
BP 1
21430 LIERNAIS
TEL.: 03.80.90.51.00
FAX: 03.80.84.43.66

DESIGNATION:
UTILISATION CLE MULTIFONCTION BFR RAL3020
FONCTION "VERROUILLAGE BFR SUR CONSOLE UNIVERSELLE"

Propriété GEWISS France - Toute reproduction et utilisation tierce requièrent l'accord écrit de GEWISS France

DESSINE PAR: NOUAILLES-LADERACH C.	VERIFIE PAR: LEGUY C.	FORMAT A4 H
DATE: 16/12/2025	ECHELLE: 1:5	
N°:	MV62750 à MV62785_01	

BOULONNERIE

CODE	DESIGNATION	QTE
MV66200	BOULON M6x10 (ERGOT+EMBASE) GEOMET	2 NR / CONS
MV66201	BOULON M6x14 (ERGOT+EMBASE) GEOMET	2 NR / CONS

BOULON M6x10 (ERGOT+EMBASE) GEOMET
 ou
 BOULON M6x14 (ERGOT+EMBASE) GEOMET



MONTAGE CHEMIN DE CABLES BRX/BRN SUR CONSOLE UNIVERSELLE MURALE

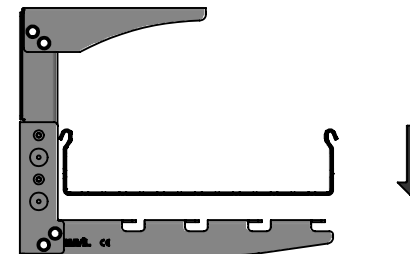

1) Positionner le chemin de cable sur la console

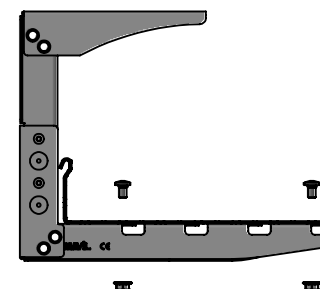

2) Boulonner le chemin de cable sur la console

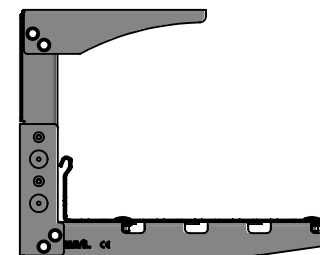

3) Le chemin de câbles est installé



Usine de Liernais
 BP 1
 21430 LIERNAIS
 TEL.: 03.80.90.51.00
 FAX: 03.80.84.43.66

DESIGNATION:

BRX/BRN HP

Propriété GEWISS France - Toute reproduction et utilisation tierce requièrent l'accord écrit de GEWISS France

DESSINE PAR: NOUAILLES-LADERACH C.	VERIFIE PAR: LEGUY C.	FORMAT A4 H
DATE: 15/12/2025	ECHELLE: 1:6	
N°: MV62750 à MV62785_01		