

TABLEAU D'AFFECTATION DE L'ECLISSE SUR CHEMIN DE CÂBLE BFR

ECLISSE AUTO BFR ECO Ø4.9	BFR60				BFR110			
	EZ		Z100		EZ		Z100	
	LARG.	CODE	LARG.	CODE	LARG.	CODE	LARG.	CODE
MV51115					300	MV50445	300	MV50545
	400	MV50436	400	MV50536	400	MV50446	400	MV50546
	500	MV50437	500	MV50537	500	MV50447	500	MV50547
	600	MV50438	600	MV50538	600	MV50448	600	MV50548

L'éclisse MV51115 se monte exclusivement sur des chemins de câbles ayant des fils de trame Ø4.9 (cf. tableau ci-dessus).
Le repère 51X15 garantit la compatibilité de l'éclisse avec ces chemins de câbles.

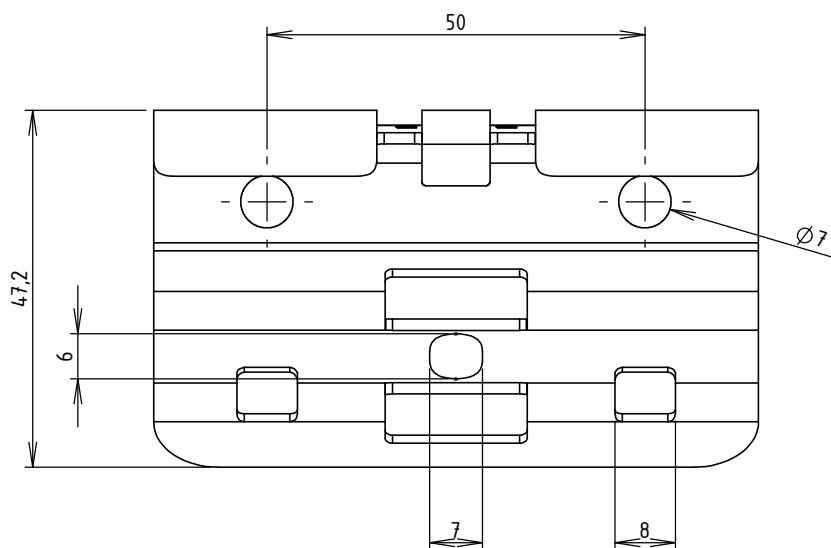

Colisage: 50 pièces
Poids net: 0.085 Kg
Matière: BANDE REFENDUE 1.50 S350GD + Z275
Revêtement: Z275 - NF EN 10346

 Usine de Liernais BP 1 21430 LIERNAIS TEL.: 03.80.90.51.00 FAX: 03.80.84.43.66	DESIGNATION:			
	ECLISSE AUTO BFR ECO Ø4.9 Z275			
	DESSINE PAR:	BERGEROT D.	VERIFIE PAR:	LEGUY C.
	DATE:	22/12/2014	ECHELLE:	1:1
N°:	MV51115_01			

FORMAT
A4 H