

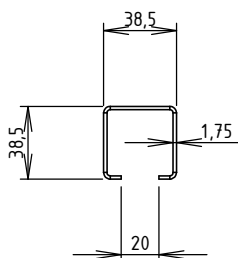

PLAN DE DEFINITION

CODE	L (mm)	POIDS NET (Kg)	COLISAGE (Pièces)
MV65190	200	0.282	50
MV65195	400	0.562	24
MV65191	500	0.703	24
MV65196	600	0.844	12
MV65197	800	1.124	12
MV65192	1000	1.406	6
MV65198	1500	2.108	6
MV65193	2000	2.816	6
MV65194	3000	4.216	4

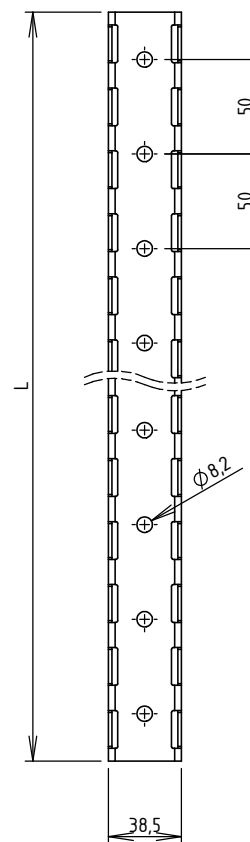
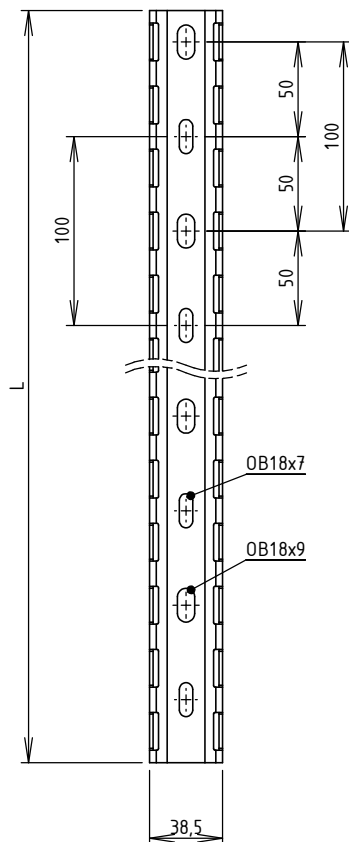

Matière: BANDE REFENDUE 1.75 S350GD + Z275 - EN 10143
 Revêtement: Z275 - NF EN 10346

 	DESIGNATION:			RAIL C40 PLURIEL Z275
	Usine de Liernais BP 1 21430 LIERNAIS TEL.: 03.80.90.51.00 FAX: 03.80.84.43.66			
DESSINE PAR:	BERGEROT D.	VERIFIE PAR:	LEGUY C.	FORMAT A4 H
DATE:	04/05/2018	ECHELLE:	1:4	
N°:	MV65190 à MV65198_03			