

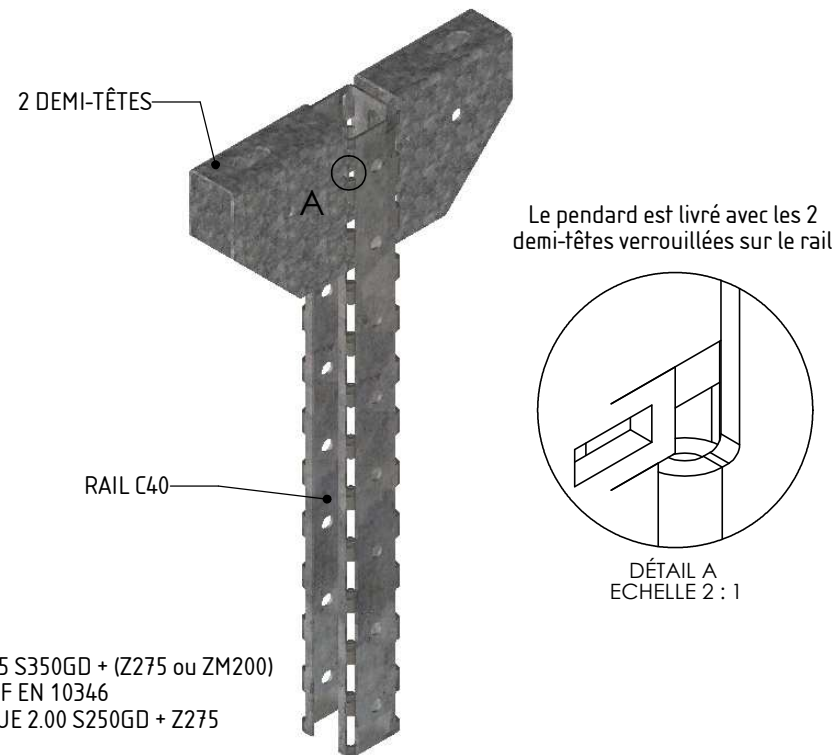

CODE	L (mm)	POIDS NET (Kg)	CHARGE ADMISSIBLE (daN.m)	COLISAGE (pièce)
MV63155	400	1.072	20	20
MV63151	500	1.213	20	20
MV63156	600	1.354	18	10
MV63157	800	1.634	18	1
MV63152	1000	1.916	14.5	1
MV63158	1500	2.618	Non communiqué ou sur demande	1

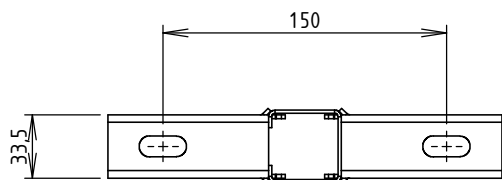

Matière rail: BANDE REFENDUE 1.75 S350GD + (Z275 ou ZM200)
 Revêtement rail: Z275 ou ZM200 - NF EN 10346
 Matière demi-tête: BANDE REFENDUE 2.00 S250GD + Z275
 Revêtement: Z275 - NF EN 10346

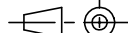

 	DESIGNATION:			
	PENDARD C40 Z275			
Usine de Liernais BP 1 21430 LIERNAIS TEL.: 03.80.90.51.00 FAX: 03.80.84.43.66	DESSINE PAR:	BERGEROT D.	VERIFIE PAR:	LEGUY C.
	DATE:	24/06/2014	ECHELLE:	1:4
	N°:	MV63151 à MV63158		
				

FORMAT
A4 H