

DÉTAIL A  
ECHELLE 1 : 1

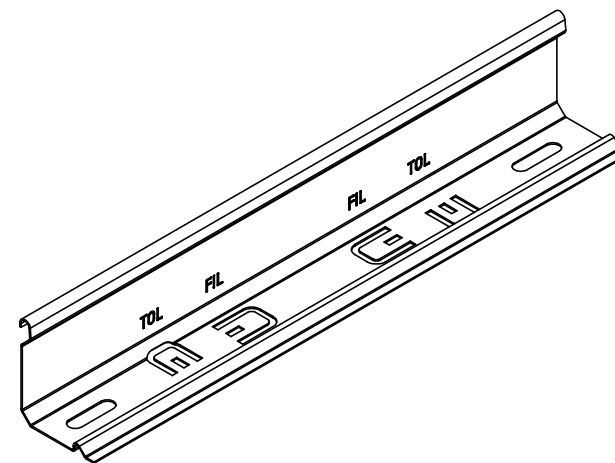

Poids (produit revêtu): 1.709 Kg  
 Colisage par 30 m  
 Matière: ACIER 0,70 S250 GD Z275  
 Revêtement: Z275 - NF EN 10346

 	DESIGNATION:			FORMAT
	SEPARATION BRN50-65 BFR60 Z275			
Usine de Liernais BP 1 21430 LIERNAIS TEL.: 03.80.90.51.00 FAX: 03.80.84.43.66	DESSINE PAR:	GUENOT F.	VERIFIE PAR:	LEGUY C.
	DATE:	12/06/2012	ECHELLE:	1:6
	N°:	MV65111x_05		

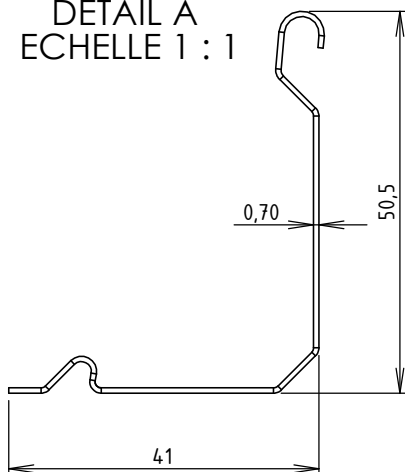