

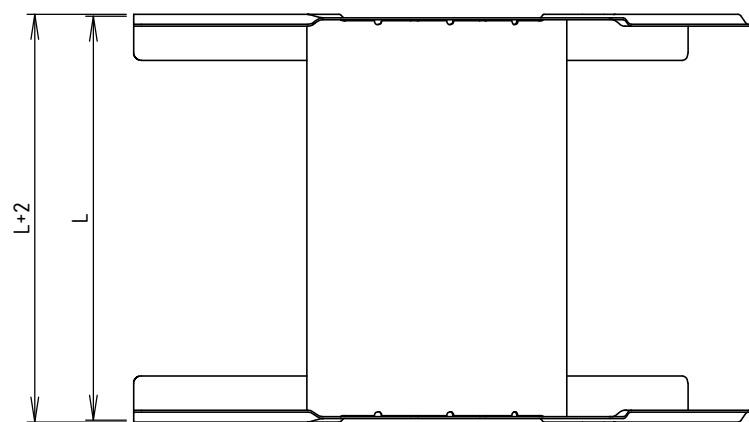

CODE	REF.	L (mm)	POIDS NET (Kg)
MVG1820GC	65	63.8	0,510
MVG1820GD	95	93.8	0,549
MVG1820GF	155	153.8	0,628
MVG1820GH	215	213.8	0,706

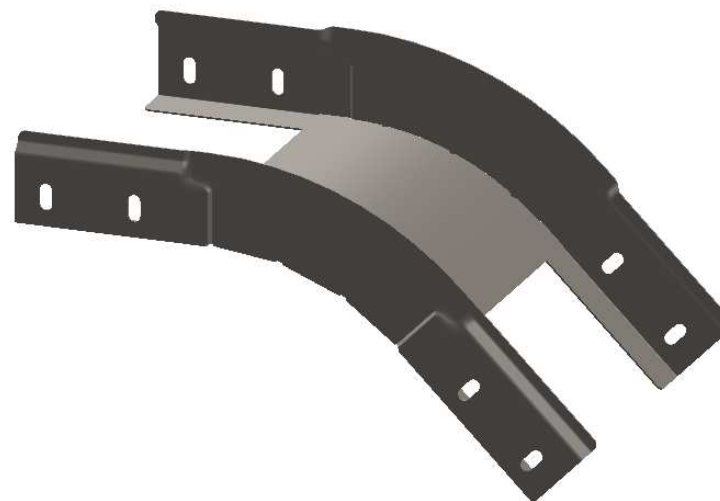
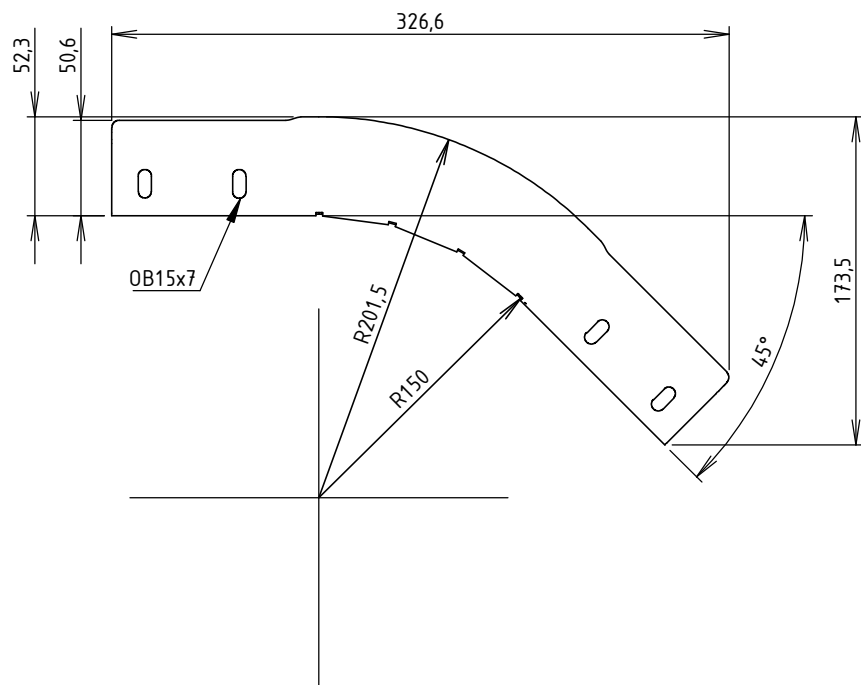

Colisage : 2 pièces  
 Assemblage réalisé par clinchage  
 Matière cornière: FEUILLE 1.00 DC01 - NF EN 10130/10131  
 Matière fond: FEUILLE 1.00 DC01 - NF EN 10130/10131  
 Revêtement:GAC - Galvanisation à chaud par immersion selon NF EN 1461  
 Dimensionnel garanti avant galvanisation

  Usine de Liernais BP 1 21430 LIERNAIS TEL.: 03.80.90.51.00 FAX: 03.80.84.43.66	DESIGNATION:			FORMAT A4 H
	COUDE CONVEXE 45° BRN50 NP R150 GAC			
	DESSINE PAR: DOS SANTOS A.	VERIFIE PAR: LEGUY C.		
	DATE: 17/02/2020	ECHELLE: 1:4		
N°:	MVG1820GC à MVG1820GH_01		