

Matière : BANDE REFENDUE S355 JR - NF EN 10025-2/10051  
 Revêtement : GAC - Galvanisation à chaud par immersion après fabrication - NF EN 1461  
 Dimensionnel garanti avant galvanisation  
 CPS : Charge Pratique de Sécurité - NF EN 61537



DESIGNATION:

CONSOLE UNIVERSELLE EN C GAC  
 CSUC

Propriété GEWISS France - Toute reproduction et utilisation tierce requièrent l'accord écrit de GEWISS France

Usine de Liernais  
 BP 1  
 21430 LIERNAIS  
 TEL.: 03.80.90.51.00  
 FAX: 03.80.84.43.66

DESSINE PAR: NOUAILLES-LADERACH C.

VERIFIE PAR:

LEGUY C.

FORMAT

DATE:

17/12/2025

ECHELLE:

1:3

A4 H

N°:

MV62250 à MV62285\_01

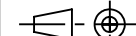

| CODE    | REF.      | H (mm) | H1 (mm) | H2 (mm) | L (mm) | e (mm) | A (mm) | B (mm) | C (mm) | D (mm) | POIDS NET (Kg) | COLISAGE (Pièces) | CPS (daN/cons) |
|---------|-----------|--------|---------|---------|--------|--------|--------|--------|--------|--------|----------------|-------------------|----------------|
| MV62250 | H150xL100 | 147.9  | 107.3   | 147.3   | 148.6  | 1.50   | 33     | 36.7   | 29.4   | 35     | 0,499          | 20                | 127            |
| MV62251 | H150xL150 | 147.9  | 107.3   | 147.3   | 198.6  | 1.50   | 33     | 36.7   | 29.4   | 35     | 0,551          | 16                | 94             |
| MV62252 | H150xL200 | 147.9  | 107.3   | 147.3   | 248.6  | 1.50   | 33     | 36.7   | 29.4   | 35     | 0,605          | 14                | 74.5           |
| MV62253 | H150xL250 | 149.2  | 108.1   | 148.1   | 299.1  | 1.75   | 33.5   | 37.2   | 29.9   | 35     | 0,760          | 12                |                |
| MV62254 | H150xL300 | 149.2  | 108.1   | 148.1   | 349.1  | 1.75   | 33.5   | 37.2   | 29.9   | 35     | 0,821          | 10                | 61             |
| MV62255 | H150xL400 | 149.2  | 108.1   | 148.1   | 449.1  | 1.75   | 33.5   | 37.2   | 29.9   | 35     | 0,944          | 14                | 47             |
| MV62256 | H200xL100 | 197.9  | 107.3   | 147.3   | 148.6  | 1.50   | 33     | 36.7   | 29.4   | 85     | 0,558          | 20                | 127            |
| MV62257 | H200xL150 | 197.9  | 107.3   | 147.3   | 198.6  | 1.50   | 33     | 36.7   | 29.4   | 85     | 0,610          | 16                | 94             |
| MV62258 | H200xL200 | 197.9  | 107.3   | 147.3   | 248.6  | 1.50   | 33     | 36.7   | 29.4   | 85     | 0,664          | 14                | 74.5           |
| MV62259 | H200xL250 | 199.2  | 108.1   | 148.1   | 299.1  | 1.75   | 33.5   | 37.2   | 29.9   | 85     | 0,829          | 12                |                |
| MV62260 | H200xL300 | 199.2  | 108.1   | 148.1   | 349.1  | 1.75   | 33.5   | 37.2   | 29.9   | 85     | 0,889          | 10                | 61             |
| MV62261 | H200xL400 | 199.2  | 108.1   | 148.1   | 449.1  | 1.75   | 33.5   | 37.2   | 29.9   | 85     | 1,013          | 14                | 47             |
| MV62262 | H230xL100 | 227.9  | 107.3   | 147.3   | 148.6  | 1.50   | 33     | 36.7   | 29.4   | 115    | 0,596          | 20                | 127            |
| MV62263 | H230xL150 | 227.9  | 107.3   | 147.3   | 198.6  | 1.50   | 33     | 36.7   | 29.4   | 115    | 0,649          | 16                | 94             |
| MV62264 | H230xL200 | 227.9  | 107.3   | 147.3   | 248.6  | 1.50   | 33     | 36.7   | 29.4   | 115    | 0,702          | 14                | 74.5           |
| MV62265 | H230xL250 | 229.2  | 108.1   | 148.1   | 299.1  | 1.75   | 33.5   | 37.2   | 29.9   | 115    | 0,873          | 12                |                |
| MV62266 | H230xL300 | 229.2  | 108.1   | 148.1   | 349.1  | 1.75   | 33.5   | 37.2   | 29.9   | 115    | 0,934          | 10                | 61             |
| MV62267 | H230xL400 | 229.2  | 108.1   | 148.1   | 449.1  | 1.75   | 33.5   | 37.2   | 29.9   | 115    | 1,057          | 16                | 47             |
| MV62268 | H300xL100 | 297.9  | 107.3   | 147.3   | 148.6  | 1.50   | 33     | 36.7   | 29.4   | 185    | 0,678          | 24                | 127            |
| MV62269 | H300xL150 | 297.9  | 107.3   | 147.3   | 198.6  | 1.50   | 33     | 36.7   | 29.4   | 185    | 0,730          | 16                | 94             |
| MV62270 | H300xL200 | 297.9  | 107.3   | 147.3   | 248.6  | 1.50   | 33     | 36.7   | 29.4   | 185    | 0,784          | 16                | 74.5           |
| MV62271 | H300xL250 | 299.2  | 108.1   | 148.1   | 299.1  | 1.75   | 33.5   | 37.2   | 29.9   | 185    | 0,967          | 8                 |                |
| MV62272 | H300xL300 | 299.2  | 108.1   | 148.1   | 349.1  | 1.75   | 33.5   | 37.2   | 29.9   | 185    | 1,027          | 8                 | 61             |
| MV62273 | H300xL400 | 299.2  | 108.1   | 148.1   | 449.1  | 1.75   | 33.5   | 37.2   | 29.9   | 185    | 1,150          | 8                 | 47             |
| MV62274 | H350xL100 | 347.9  | 107.3   | 147.3   | 148.6  | 1.50   | 33     | 36.7   | 29.4   | 235    | 0,736          | 16                | 127            |
| MV62275 | H350xL150 | 347.9  | 107.3   | 147.3   | 198.6  | 1.50   | 33     | 36.7   | 29.4   | 235    | 0,789          | 8                 | 94             |
| MV62276 | H350xL200 | 347.9  | 107.3   | 147.3   | 248.6  | 1.50   | 33     | 36.7   | 29.4   | 235    | 0,842          | 8                 | 74.5           |
| MV62277 | H350xL250 | 349.2  | 108.1   | 148.1   | 299.1  | 1.75   | 33.5   | 37.2   | 29.9   | 235    | 1,035          | 8                 |                |
| MV62278 | H350xL300 | 349.2  | 108.1   | 148.1   | 349.1  | 1.75   | 33.5   | 37.2   | 29.9   | 235    | 1,096          | 8                 | 61             |
| MV62279 | H350xL400 | 349.2  | 108.1   | 148.1   | 449.1  | 1.75   | 33.5   | 37.2   | 29.9   | 235    | 1,219          | 8                 | 47             |
| MV62280 | H400xL100 | 397.9  | 107.3   | 147.3   | 148.6  | 1.50   | 33     | 36.7   | 29.4   | 285    | 0,796          | 16                | 127            |
| MV62281 | H400xL150 | 397.9  | 107.3   | 147.3   | 198.6  | 1.50   | 33     | 36.7   | 29.4   | 285    | 0,849          | 8                 | 94             |
| MV62282 | H400xL200 | 397.9  | 107.3   | 147.3   | 248.6  | 1.50   | 33     | 36.7   | 29.4   | 285    | 0,902          | 8                 | 74.5           |
| MV62283 | H400xL250 | 399.2  | 108.1   | 148.1   | 299.1  | 1.75   | 33.5   | 37.2   | 29.9   | 285    | 1,104          | 8                 |                |
| MV62284 | H400xL300 | 399.2  | 108.1   | 148.1   | 349.1  | 1.75   | 33.5   | 37.2   | 29.9   | 285    | 1,165          | 8                 | 61             |
| MV62285 | H400xL400 | 399.2  | 108.1   | 148.1   | 449.1  | 1.75   | 33.5   | 37.2   | 29.9   | 285    | 1,288          | 20                | 47             |



Usine de Liernais  
BP 1  
21430 LIERNAIS  
TEL.: 03.80.90.51.00  
FAX: 03.80.84.43.66

DESIGNATION:

CONSOLE UNIVERSELLE EN C GAC  
CSUC

Propriété GEWISS France - Toute reproduction et utilisation tierce requièrent l'accord écrit de GEWISS France

DESSINE PAR: NOUAILLES-LADERACH C.

VERIFIE PAR:

LEGUY C.

FORMAT

DATE:

13/11/2020

ECHELLE:

1:4

A4 V

N°:

MV62250 à MV62285\_01

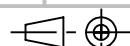

## FIXATION AU MUR

| CODE    | DESIGNATION                | QTE         |
|---------|----------------------------|-------------|
| MV66278 | RONDELLE PLATE M 10 GEOMET | 1 NR / CONS |

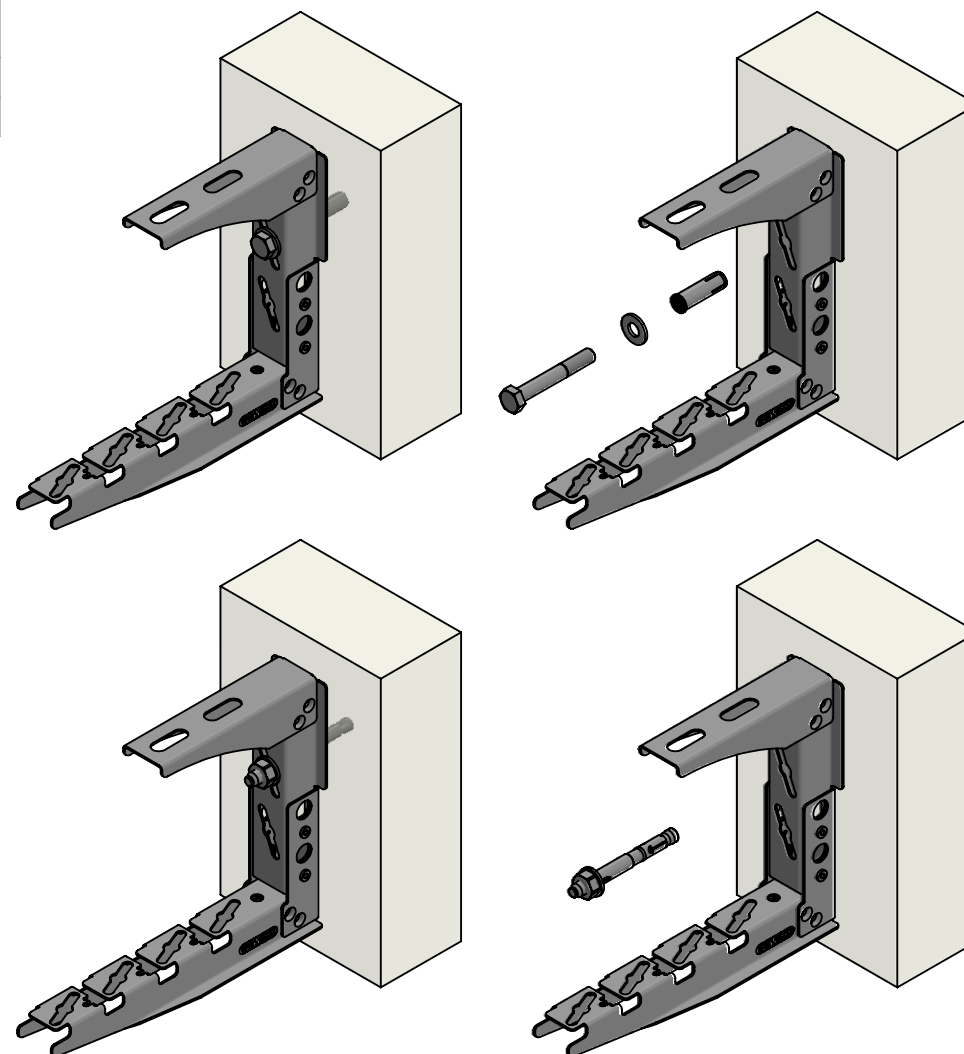
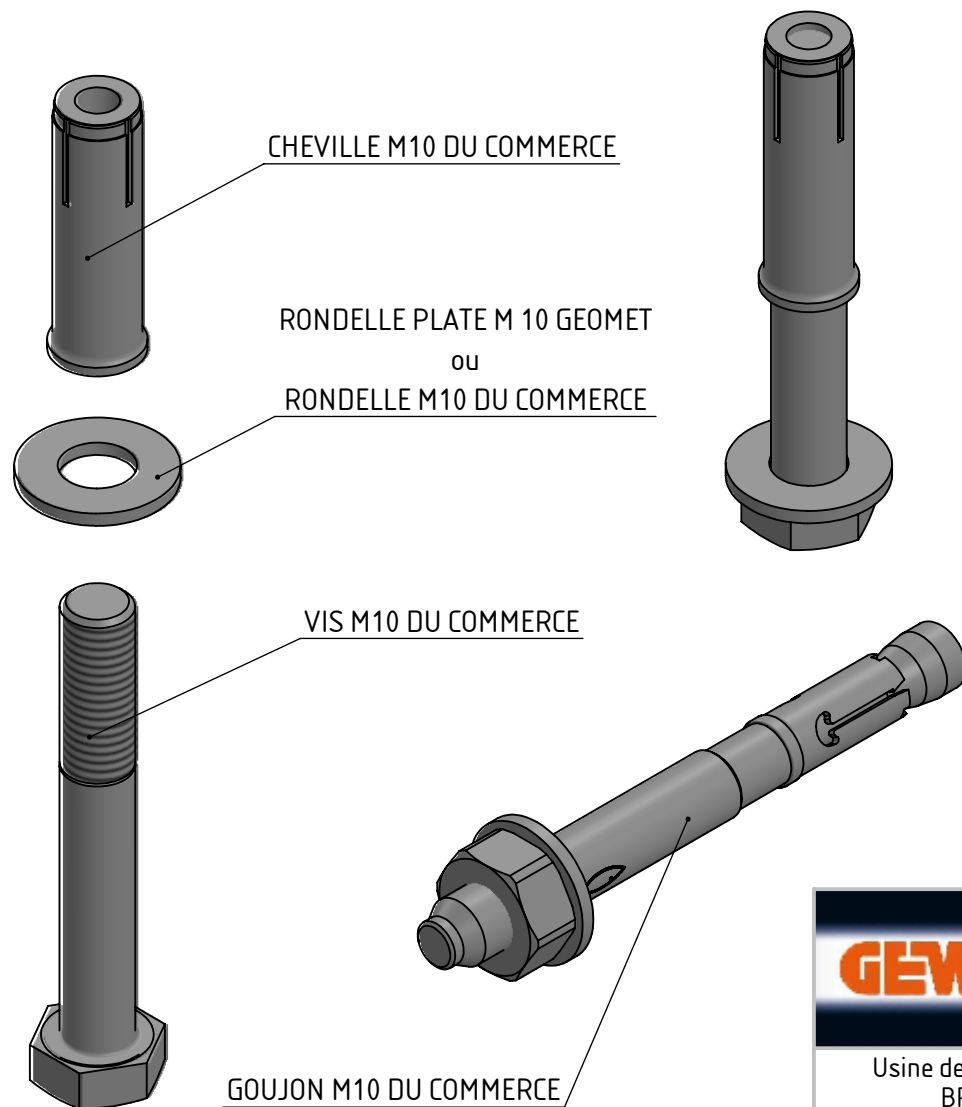

Usine de Liernais  
BP 1  
21430 LIERNAIS  
TEL.: 03.80.90.51.00  
FAX: 03.80.84.43.66

DESIGNATION:

FIXATION AU MUR GAC

Propriété GEWISS France - Toute reproduction et utilisation tierce requièrent l'accord écrit de GEWISS France

|                                    |                       |                |
|------------------------------------|-----------------------|----------------|
| DESSINE PAR: NOUAILLES-LADERACH C. | VERIFIE PAR: LEGUY C. | FORMAT<br>A4 H |
| DATE: 16/12/2025                   | ECHELLE: 1:5          |                |
| N°:                                | MV62250 à MV62285_01  |                |

## FIXATION AU PLAFOND

| CODE    | DESIGNATION                | QTE         |
|---------|----------------------------|-------------|
| MV66278 | RONDELLE PLATE M 10 GEOMET | 1 NR / CONS |

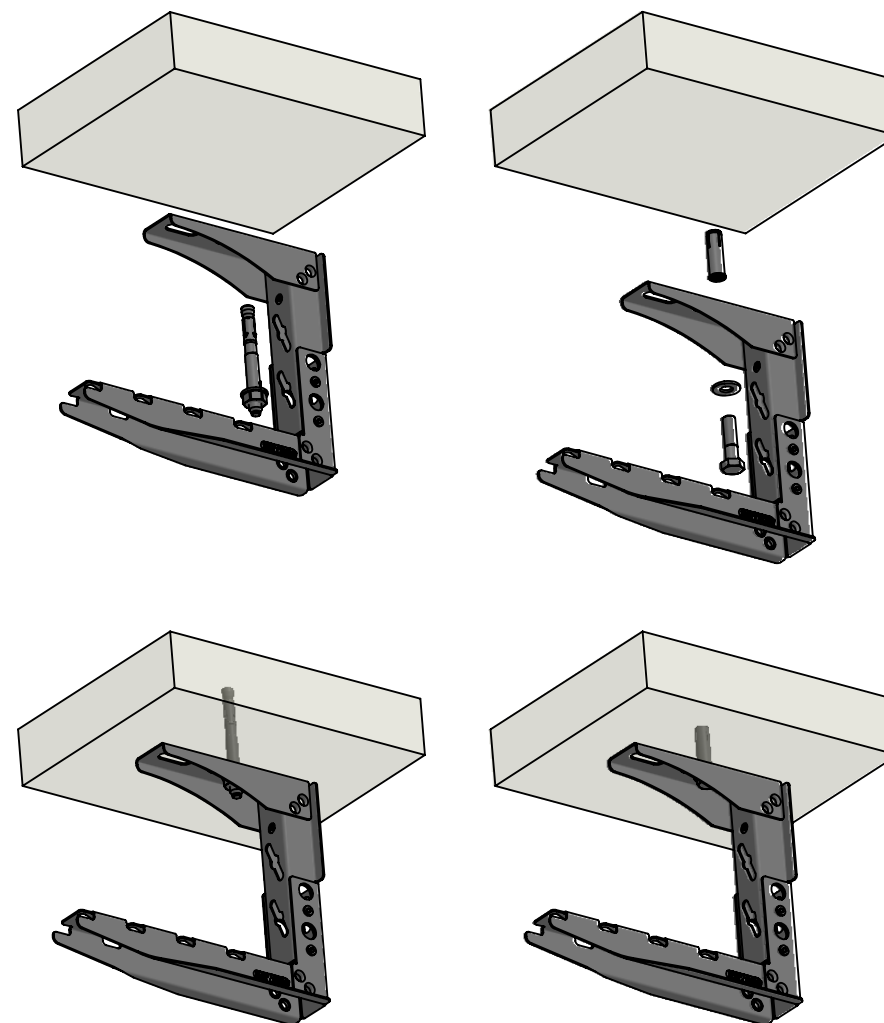
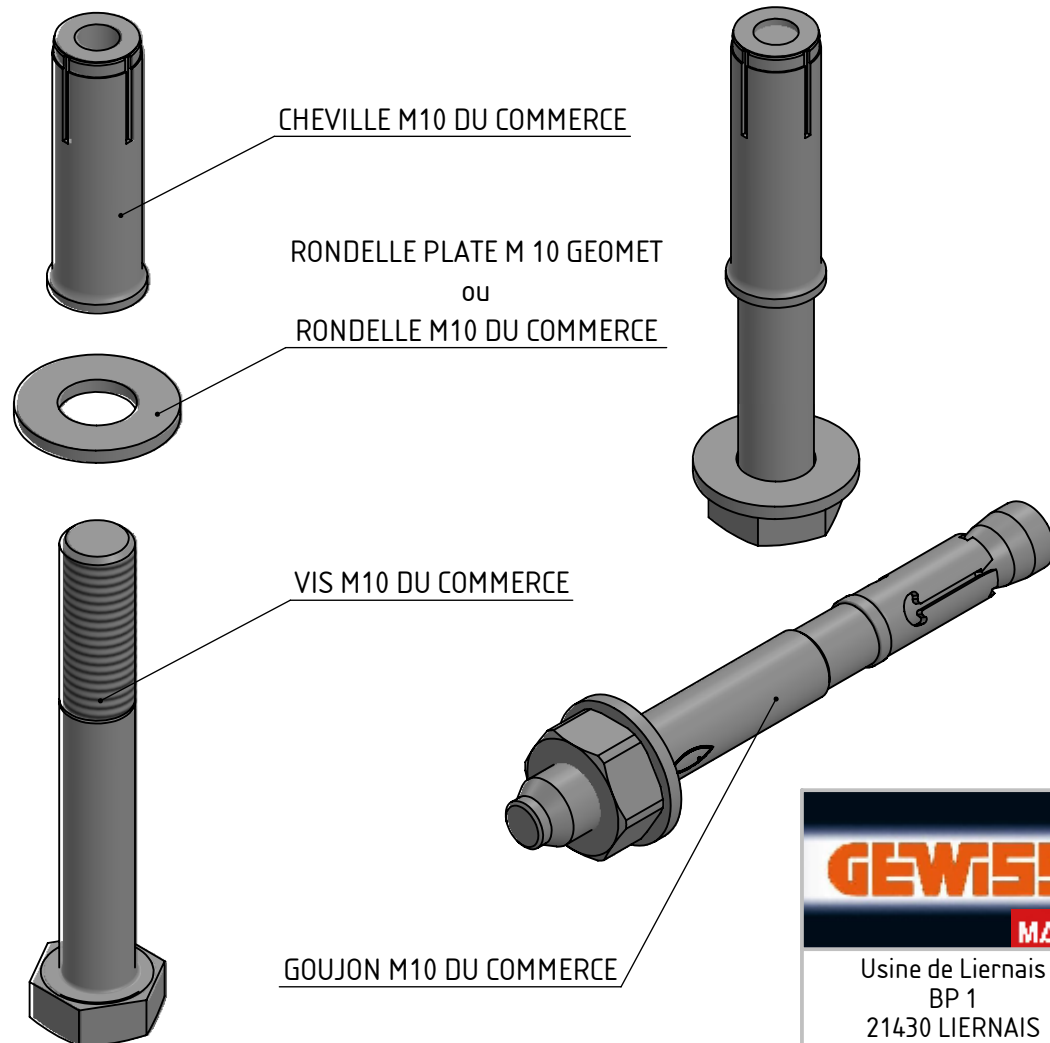

Usine de Liernais  
BP 1  
21430 LIERNAIS  
TEL.: 03.80.90.51.00  
FAX: 03.80.84.43.66

DESIGNATION:

FIXATION AU PLAFOND GAC

Propriété GEWISS France - Toute reproduction et utilisation tierce requièrent l'accord écrit de GEWISS France

|                                    |                       |                |
|------------------------------------|-----------------------|----------------|
| DESSINE PAR: NOUAILLES-LADERACH C. | VERIFIE PAR: LEGUY C. | FORMAT<br>A4 H |
| DATE: 16/12/2025                   | ECHELLE: 1:6          |                |
| N°:                                | MV62250 à MV62285_01  |                |

VERROUILLAGE CHEMIN DE CABLES BFR SUR CONSOLE UNIVERSELLE MURALE

MONTAGE CHEMIN DE CABLES BFR SUR CONSOLE UNIVERSELLE MURALE

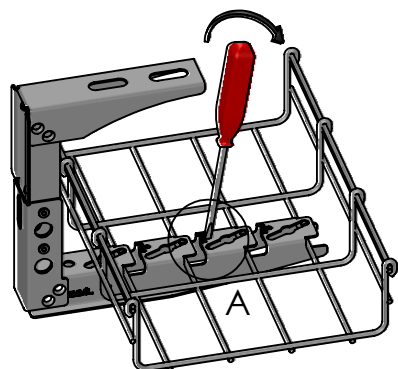

1) Introduire un tournevis dans la perfo des languettes de verrouillage

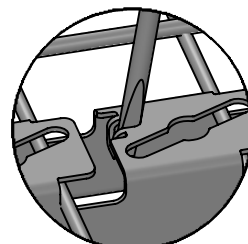

DÉTAIL A  
ECHELLE 1 : 2

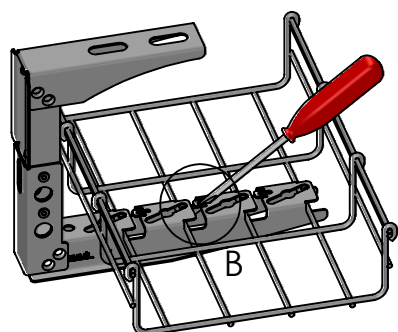

2) Faire pivoter le tournevis de façon à relever les languettes de verrouillage

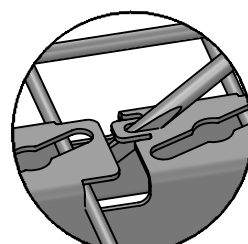

DÉTAIL B  
ECHELLE 1 : 2

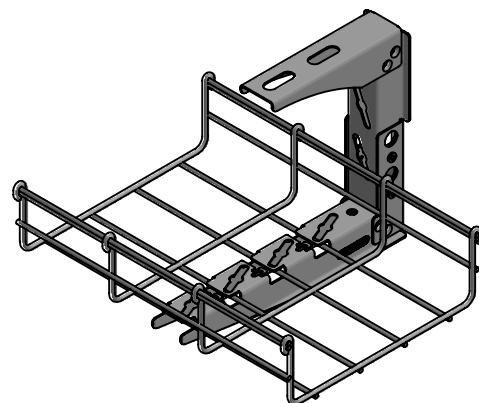

3) Le chemin de câbles est verrouillé sur la console

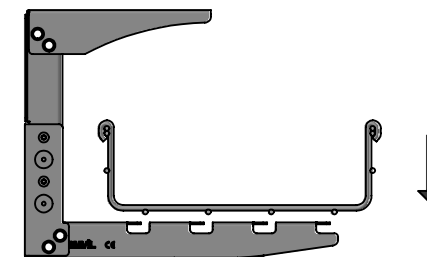

1) Introduire le chemin de câbles dans les encoches de la console

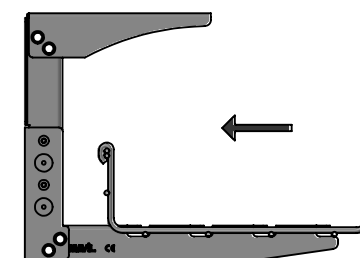

2) Faire coulisser le chemin de câbles dans les encoches de la console

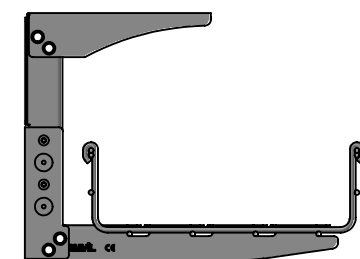

3) Le chemin de câbles est installé, sans être verrouillé



Usine de Liernais  
BP 1  
21430 LIERNAIS  
TEL.: 03.80.90.51.00  
FAX: 03.80.84.43.66

DESIGNATION:

BFR

Propriété GEWISS France - Toute reproduction et utilisation tierce requièrent l'accord écrit de GEWISS France

DESSINE PAR: NOUAILLES-LADERACH C.

VERIFIE PAR:

LEGUY C.

FORMAT

DATE:

15/12/2025

ECHELLE:

1:6

A4 H

N°:

MV62250 à MV62285\_01

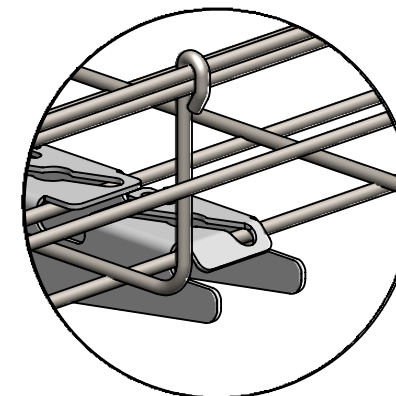
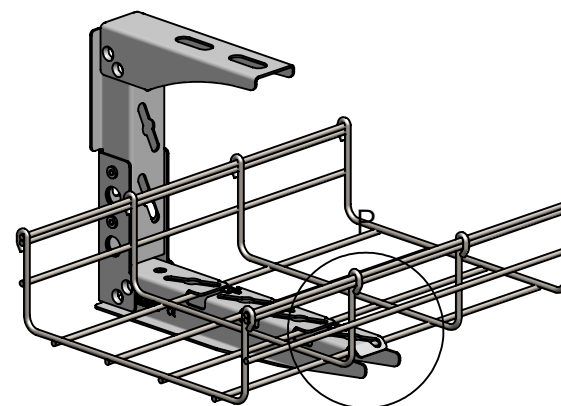
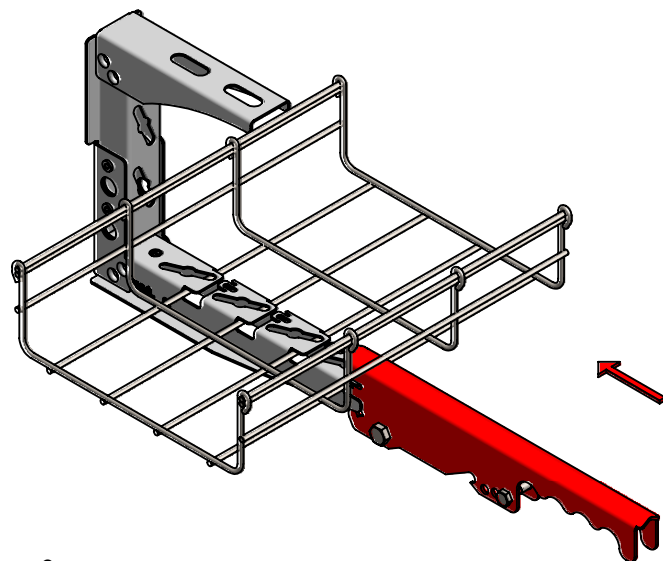

## Etape 1

DÉTAIL P  
ECHELLE 1 : 2

Etape 1 : insérer la clé en bout de console universelle (MV60x80 à MV60x85 et MV60x90 à MV60x95) de manière à pincer le fil et la console dans l'encoche prévue à cet effet.

Etape 2 : exercer une pression vers le bas sur la clé tout en maintenant la console en place pour déformer l'extrémité de la console >>> Le chemin de câbles est verrouillé.

Cette fonction permet de réaliser une déformation permanente de l'extrémité de la console afin de verrouiller totalement le chemin de câbles sur cette dernière.



Usine de Liernais  
BP 1  
21430 LIERNAIS  
TEL.: 03.80.90.51.00  
FAX: 03.80.84.43.66

DESIGNATION:  
UTILISATION CLE MULTIFONCTION BFR RAL3020  
FONCTION "VERROUILLAGE BFR SUR CONSOLE UNIVERSELLE"

Propriété GEWISS France - Toute reproduction et utilisation tierce requièrent l'accord écrit de GEWISS France

|                                    |                       |                |
|------------------------------------|-----------------------|----------------|
| DESSINE PAR: NOUAILLES-LADERACH C. | VERIFIE PAR: LEGUY C. | FORMAT<br>A4 H |
| DATE: 16/12/2025                   | ECHELLE: 1:5          |                |
| N°:                                | MV62250 à MV62285_01  |                |

# BOULONNERIE

| CODE    | DESIGNATION                        | QTE         |
|---------|------------------------------------|-------------|
| MV66200 | BOULON M6x10 (ERGOT+EMBASE) GEOMET | 2 NR / CONS |
| MV66201 | BOULON M6x14 (ERGOT+EMBASE) GEOMET | 2 NR / CONS |

BOULON M6x10 (ERGOT+EMBASE) GEOMET  
 ou  
 BOULON M6x14 (ERGOT+EMBASE) GEOMET



## MONTAGE CHEMIN DE CABLES BRX/BRN SUR CONSOLE UNIVERSELLE MURALE

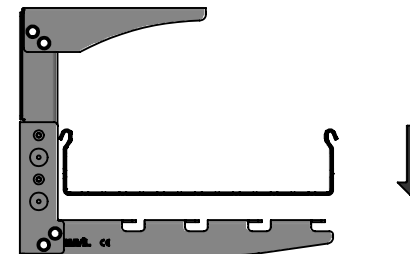

1) Positionner le chemin de cable sur la console

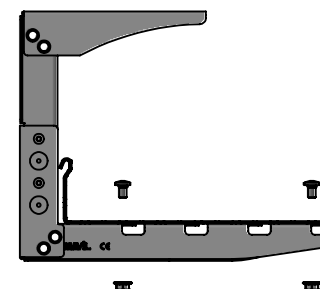

2) Boulonner le chemin de cable sur la console

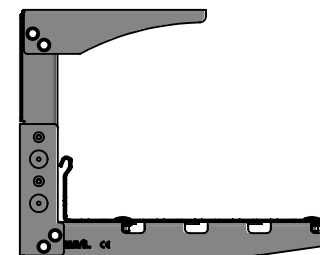

3) Le chemin de câbles est installé



Usine de Liernais  
 BP 1  
 21430 LIERNAIS  
 TEL.: 03.80.90.51.00  
 FAX: 03.80.84.43.66

DESIGNATION:

BRX/BRN GAC

Propriété GEWISS France - Toute reproduction et utilisation tierce requièrent l'accord écrit de GEWISS France

|                                    |                       |                |
|------------------------------------|-----------------------|----------------|
| DESSINE PAR: NOUAILLES-LADERACH C. | VERIFIE PAR: LEGUY C. | FORMAT<br>A4 H |
| DATE: 15/12/2025                   | ECHELLE: 1:6          |                |
| N°: MV62250 à MV62285_01           |                       |                |