

CODE	REF.	L (mm)	L1 (mm)	L2 (mm)	POIDS NET (Kg)	COLISAGE (NR)
MVN1270GL	305	438.3	303.8	536.3	1.297	10
MVN1270GP	395	528.4	393.8	600	1.661	10
MVN1270GU	515	648.4	513.8	684.8	2.232	6
MVN1270GX	605	738.4	603.8	748.5	2.717	4

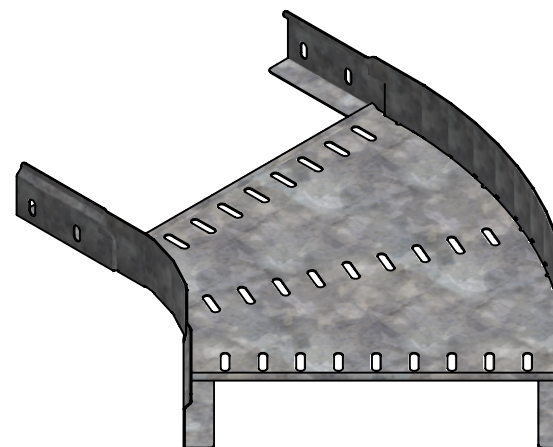

Assemblage réalisé par clinchage
 Matière cornière: BD REFENDUE 1.00 DX51D + ZM250 - NF EN 10143/10346
 Matière fond: FEUILLE 1.00 DX51D + ZM250 - NF EN 10143/10346
 Revêtement: ZM250 - NF EN 10346

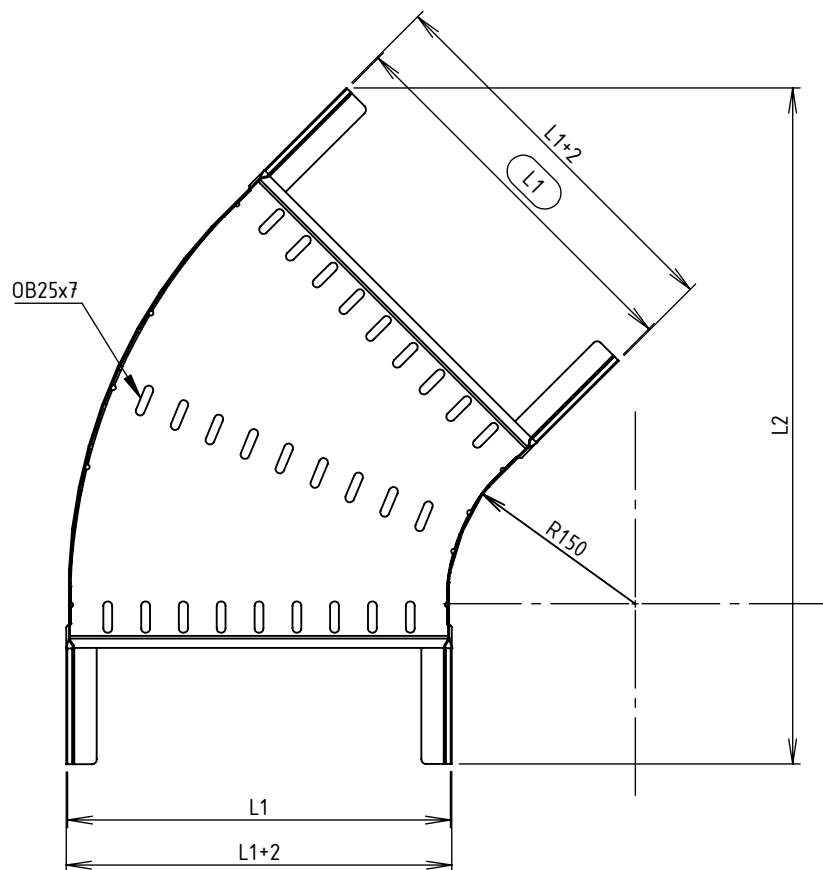

Usine de Liernais
 BP 1
 21430 LIERNAIS
 TEL.: 03.80.90.51.00
 FAX: 03.80.84.43.66

DESIGNATION:

COUDE 135° BRX/BRN50 R150 HP

Propriété GEWISS France - Toute reproduction et utilisation tierce requièrent l'accord écrit de GEWISS France

DESSINE PAR:	BERGEROT D.	VERIFIE PAR:	LEGUY C.	FORMAT A4 H
DATE:	16/01/2024	ECHELLE:	1:6	
N°:	MVN1270GL à MVN1270GX_01			