

ECLISSE AUTO BFR ECO Ø4.9 Z275		CC BFR60 Z100						CC BFR60 PRE-ECLISSE Z100					
CODE	POIDS NET (Kg)	CODE	L (mm)	H (mm)	ØC (mm)	A (mm)	POIDS NET (Kg)	CPS portée 1.5/2.0/2.5 m (daN/m)	CODE	L (mm)	POIDS NET (Kg)	COLISAGE	
												CC BFR60 (m)	ECLISSE (NR)
MV51115	0.085	MV50536	400	75.7	4.5	26.6	8.718	82.8/60.9/44.5	MV50586	400	8.888	6	4
		MV50537	500				9.941	92.5/78.5/48.5	MV50587	500	10.111		
		MV50538	600	74.7	4.9	27.4	12.559	86.2/71.5/48.3	MV50588	600	12.729		

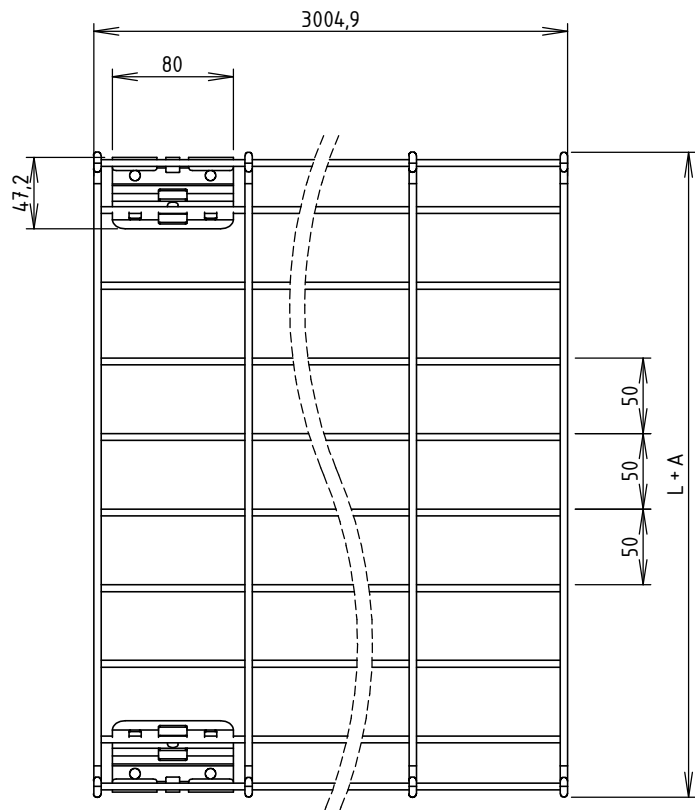

CC BFR60 Z100 (MV50536 à MV50538)

ECLISSE AUTO BFR ECO Ø4.9 Z275 (MV51115)

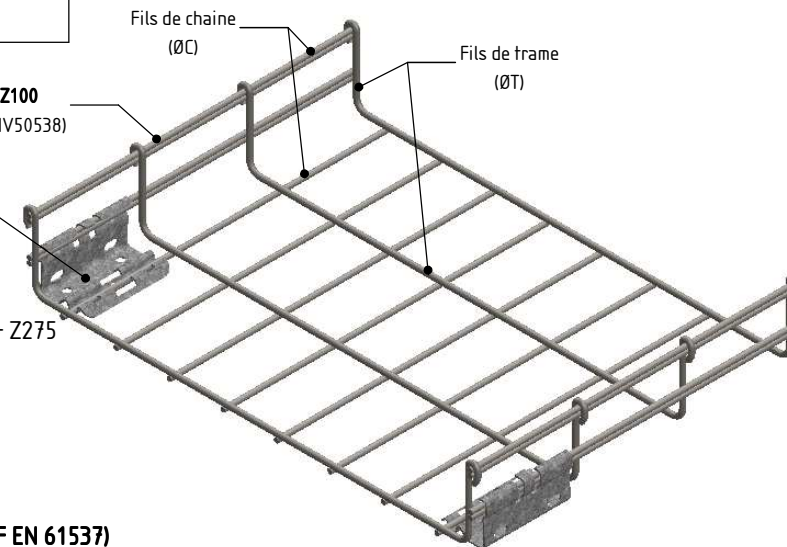

ECLISSE AUTO BFR ECO Ø4.9 Z275:

Matière: BANDE REFENDUE 1.50 S350GD + Z275
 Revêtement: Z275 - NF EN 10346

CC BFR60 Z100:

Matière: FIL Ø4.5 C9D - NF EN 16120-2
 : FIL Ø4.9 C9D - NF EN 16120-2
 Revêtement: Z100 - NF EN 10244-2

CPS (Charge Pratique de Sécurité selon NF EN 61537)

	DESIGNATION:		CC BFR60 PRE-ECLISSE Z100	
	Usine de Liernais BP 1 21430 LIERNAIS TEL.: 03.80.90.51.00 FAX: 03.80.84.43.66	DESSINE PAR: BERGEROT D.	VERIFIE PAR: LEGUY C.	FORMAT A4 H
	DATE: 15/09/2016	ECHELLE: 1:5		
	N°:	MV50586 à MV50588_02	