

CODE	REF.	L (mm)	L1 (mm)	L2 (mm)	POIDS NET (Kg)	COLISAGE (NR)
MVN1470GL	305	850.8	303.8	341.4	1.429	10
MVN1470GP	395	940.8	393.8	341.4	1.604	10
MVN1470GU	515	1086.8	513.8	354.4	1.926	8
MVN1470GX	605	1150.8	603.8	341.4	2.014	8

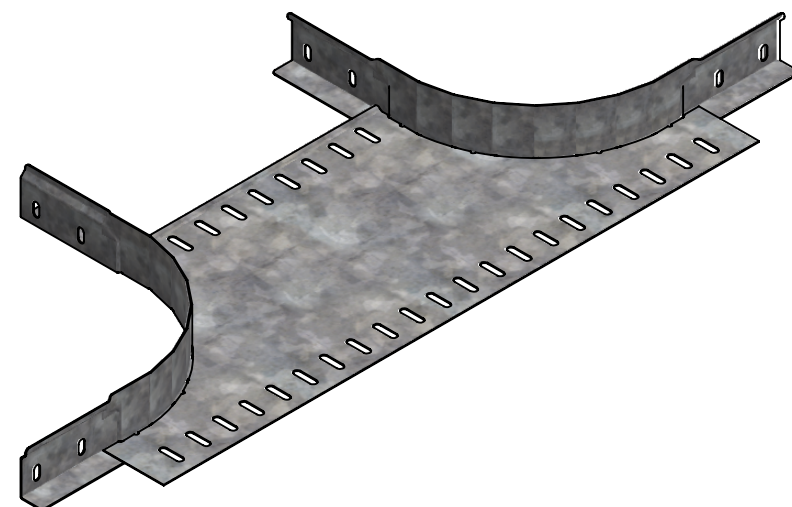

Assemblage réalisé par clinchage
 Matière cornière: BANDE REFENDUE 1.00 DX51D + ZM250 - NF EN 10143/10346
 Matière fond: FEUILLE 1.00 DX51D + ZM250 - NF EN 10143/10346
 Revêtement: ZM250 - NF EN 10346

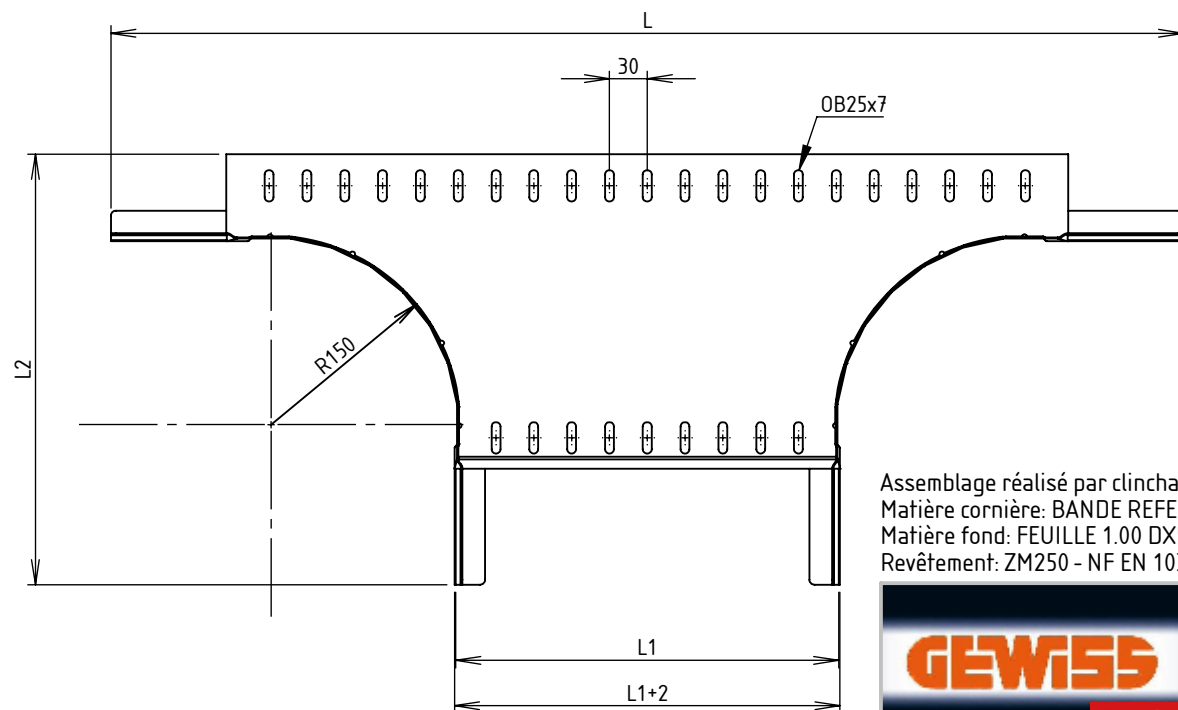
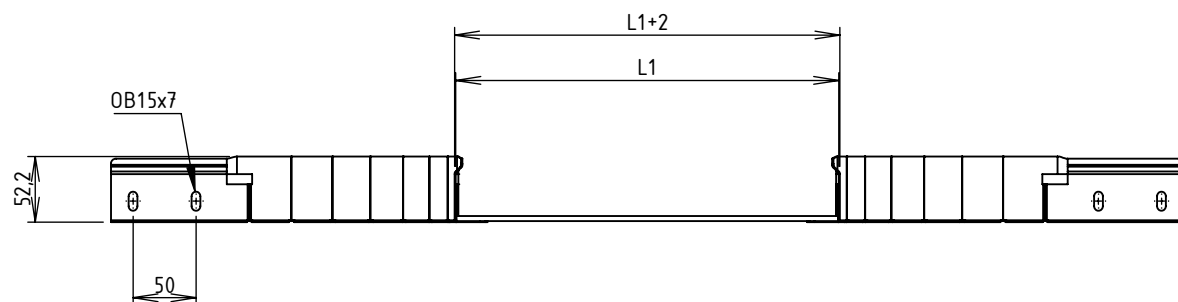

Usine de Liernais
 BP 1
 21430 LIERNAIS
 TEL.: 03.80.90.51.00
 FAX: 03.80.84.43.66

DESIGNATION: SORTIE LAT BRX50 R150 HP
 Propriété GEWISS France - Toute reproduction et utilisation tierce requièrent l'accord écrit de GEWISS France

DESSINE PAR:	BERGEROT D.	VERIFIE PAR:	LEGUY C.	FORMAT A4 H
DATE:	17/01/2024	ECHELLE:	1:6	
N°:	MVN1470GL à MVN1470GX_01			