

DÉTAIL A  
ECHELLE 1 : 4

CODE	L (mm)	Poids (kg)
MV99131	100	3.76
MV99132	200	3.99
MV99133	300	4.30
MV99134	400	4.70
MV99135	500	4.93
MV99136	600	5.21

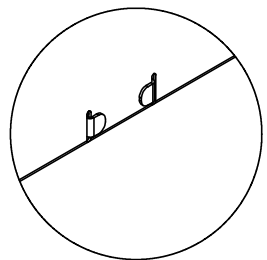

Plage d'articulation: de -90° à 90°  
 Matière: TÔLE GALVA 1.50 DX51D + Z275  
 Revêtement: Z275 - NF EN 10346

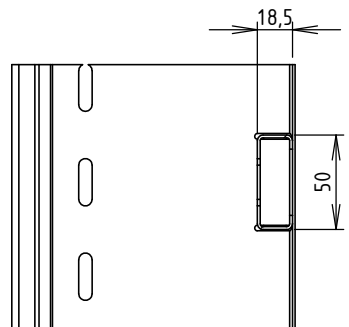

DÉTAIL C  
ECHELLE 1 : 4



COUPE B-B  
ECHELLE 1 : 4

  Usine de Liernais BP 1 21430 LIERNAIS TEL.: 03.80.90.51.00 FAX: 03.80.84.43.66	DESIGNATION:			FORMAT A4 H	
	COUDE ARTICULE VERTI ML150 Z275				
	DESSINE PAR:	BONIN G.	VERIFIE PAR:		BERGEROT D.
	DATE:	02/11/2015	ECHELLE:		1:12
N°:	MV99131 à MV99136		