

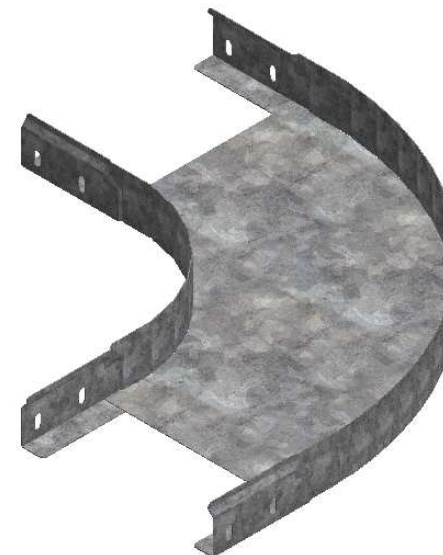

CODE	REF.	L (mm)	L1 (mm)	POIDS NET (Kg)	COLISAGE (NR)
MVG1110GC	65	338.4	63.8	0,777	10
MVG1110GD	95	368.4	93.8	0,901	10
MVG1110GF	155	428.4	153.8	1,173	10
MVG1110GH	215	488.4	213.8	1,481	10

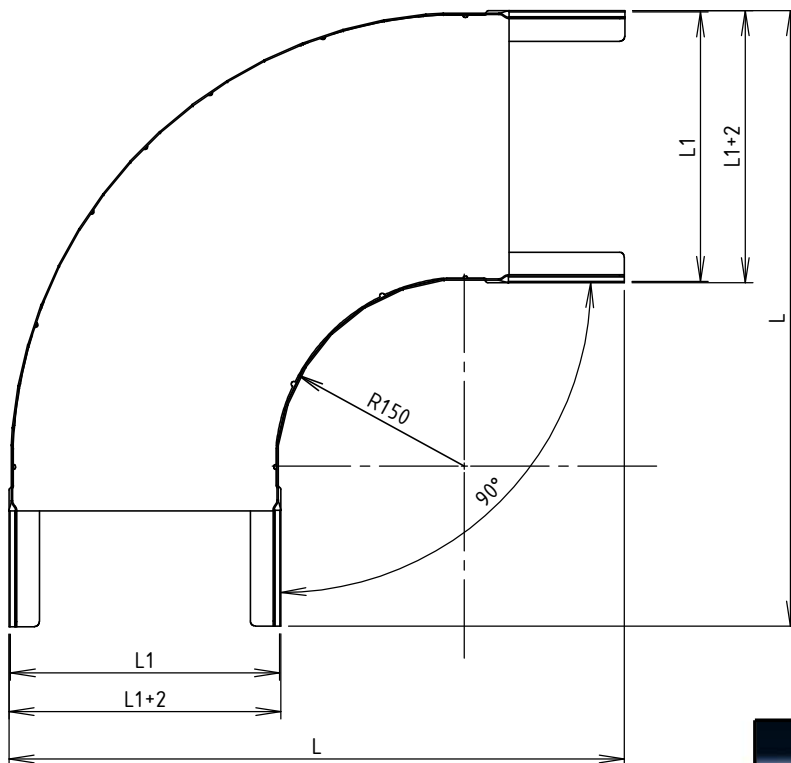

Assemblage réalisé par clinchage
 Matière cornière: BD REFENDUE 1,00 DX51D + Z275 - NF EN 10143/10346
 Matière fond: FEUILLE 0.90 DX51D + Z275 - NF EN 10143/10346
 Revêtement: Z275 - NF EN 10346

  Usine de Liernais BP 1 21430 LIERNAIS TEL.: 03.80.90.51.00 FAX: 03.80.84.43.66	DESIGNATION:		COUDE 90° BRN50 NP R150 Z275		
	Propriété GEWISS France - Toute reproduction et utilisation tierce requièrent l'accord écrit de GEWISS France				
	DESSINE PAR:	DOS SANTOS A.	VERIFIE PAR:	LEGUY C.	FORMAT A4 H
	DATE:	12/02/2020	ECHELLE:	1:6	
N°:	MVG1110GC à MVG1110GH_01			