

DÉTAIL A
ECHELLE 1 : 4

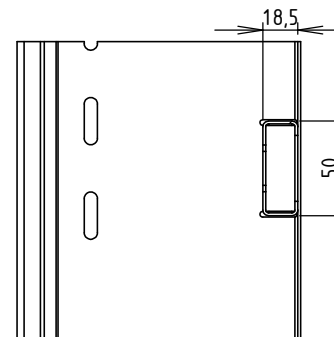

COUPE C-C
ECHELLE 1 : 4

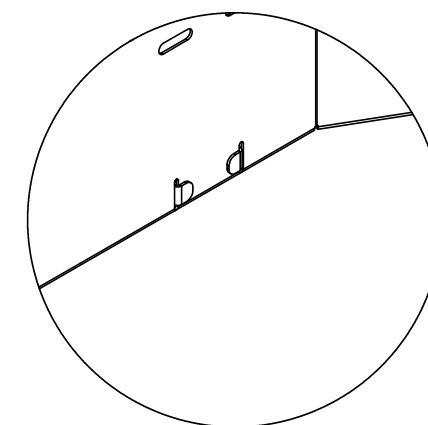

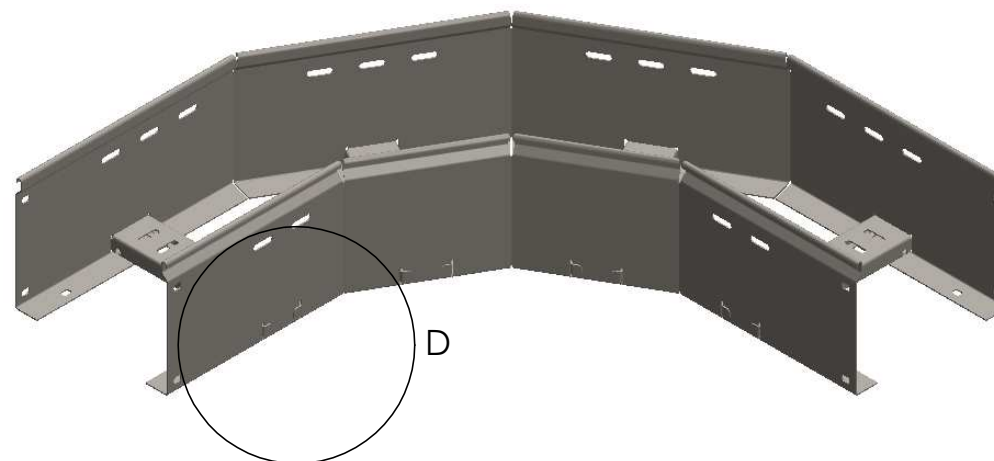
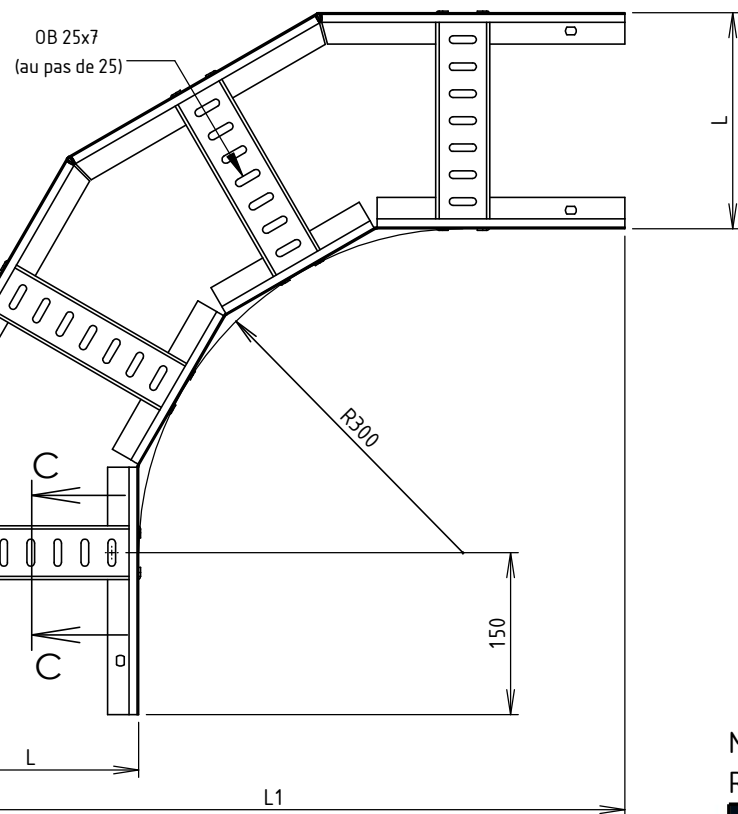

DÉTAIL D
ECHELLE 1 : 4



Matière: TÔLE NOIRE 1.50 S235 JR
Revêtement: GAC - NF EN ISO 1461

CODE	L (mm)	L1 (mm)	Poids (kg)
MV92231	100	550	
MV92232	200	650	
MV92233	300	750	
MV92234	400	850	
MV92235	500	950	
MV92236	600	1050	

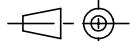
  Usine de Liernais BP 1 21430 LIERNAIS TEL.: 03.80.90.51.00 FAX: 03.80.84.43.66	DESIGNATION:		COUDE 90° EAC ML 150 GAC	
	DESSINE PAR:	BONIN G.	VERIFIE PAR:	BERGEROT D.
	DATE:	22/10/2015	ECHELLE:	1:7
	N°:	MV92231 à MV92236		
				FORMAT A4 H