

ECLISSE AUTO BFR ECO Ø3.9 GAC		CC BFR30 GAC				CC BFR30 PRE-ECLISSE GAC					
CODE	POIDS NET (Kg)	CODE	L (mm)	H (mm)	POIDS NET (Kg)	CPS portée 1.5/2.0/2.5 m (daN/m)	CODE	L (mm)	POIDS NET (Kg)	COLISAGE	
										CC BFR30 (m)	ECLISSE (NR)
MV51213	0.089	MV50220	50	42.2	1.227	8/6/4	MV50270	50	1.316	30	10
		MV50221	100		1.638		MV50271	100	1.816		20
		MV50222	150		2.611	11/7.5/5	MV50272	150	2.789	18	12
		MV50223	200		3.022	15/10/7.5	MV50273	200	3.200	12	8

Chaque longueur de chemin de câbles est livrée avec 2 éclisses.
Sauf pour la largeur 50, livrée avec 1 seule éclisse (voir colisage)

ECLISSE AUTO BFR ECO Ø3.9 GAC:

Matière: BANDE REFENDUE 1.50 S355 JR

Revêtement: GAC - NF EN ISO 1461



CC BFR30 GAC:

Matière: FIL CLAIR Ø3.7 C9D CLASSE 1 - NF EN 16120-2

Revêtement: GAC - NF EN ISO 1461

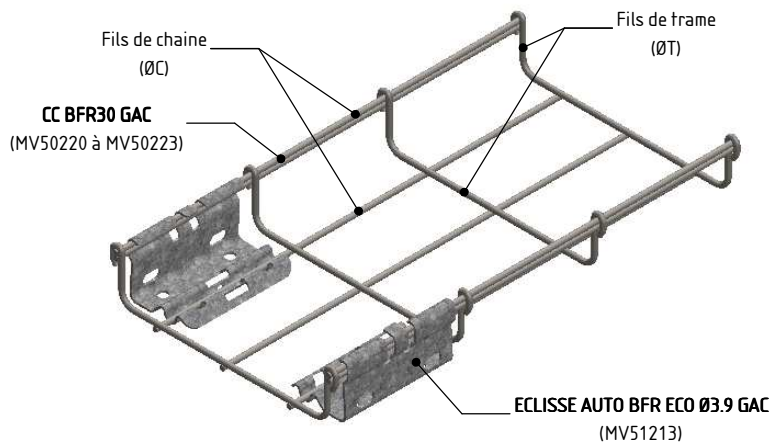
CPS (Charge Pratique de Sécurité selon NF EN 61537)



 	DESIGNATION:				
	CC BFR30 PRE-ECLISSE GAC				
Usine de Liernais BP 1 21430 LIERNAIS TEL.: 03.80.90.51.00 FAX: 03.80.84.43.66	DESSINE PAR:	BERGEROT D.	VERIFIE PAR:	LEGUY C.	FORMAT A4 H
	DATE:	16/09/2016	ECHELLE:	1:4	
	N°:	MV50270 à MV50273_02			