

ARTICLE					COMPOSANTS ARTICLE							
CC BRX50 PRET-A-POSER Z275					CC BRX50 Z275			ECLISSE AUTO BRX50 Z275 VRAC				
CODE	DESIGNATION	REF.	LARG (mm)	POIDS NET (Kg)	CODE	Ep (mm)	POIDS NET (Kg)	CPS (daN/m)			CODE	POIDS NET (Kg)
								Portée (m)				
								1.5	2.0	2.5		
MVX0213GD	CC 95 BRX50 PRET-A-POSER Z275	95	93.8	3.123	MVX40121	0.6	2.895	65	39	25	406029173	0.114
MVX0213GF	CC 155 BRX50 PRET-A-POSER Z275	155	153.8	3.922	MVX40123	0.6	3.694	75.5	51.5	33		
MVX0213GH	CC 215 BRX50 PRET-A-POSER Z275	215	213.8	4.721	MVX40125	0.6	4.493	75.5	51.5	33		
MVX0213GL	CC 305 BRX50 PRET-A-POSER Z275	305	303.8	6.815	MVX40128	0.7	6.587	85	60	52		
MVX0213GP	CC 395 BRX50 PRET-A-POSER Z275	395	393.8	10.372	MVX40131	0.9	10.144	100*	80*	58*		
MVX0213GU	CC 515 BRX50 PRET-A-POSER Z275	515	513.8	12.724	MVX40135	0.9	12.496	108*	84.5*	64*		
MVX0213GX	CC 605 BRX50 PRET-A-POSER Z275	605	603.8	14.488	MVX40137	0.9	14.260	108*	84.5*	64*		

*: Valeur de CPS indiquée avec installation d'un couvre joint

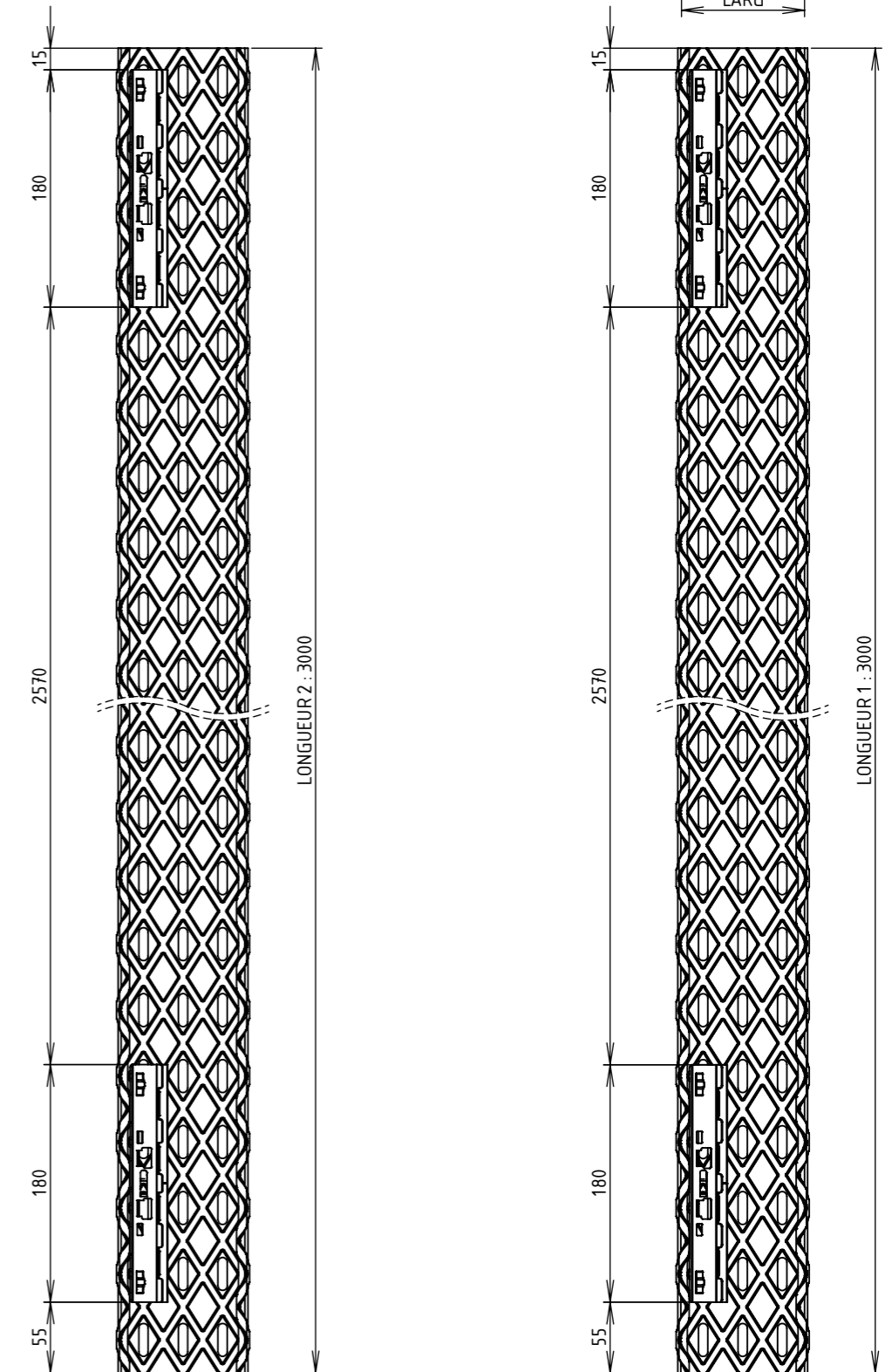

Matière cc: BOBINE DX51D + Z275 - NF EN 10143/10346
 Matière éclisse: BANDE REFENDUE 1.00 DX51D + Z275 - NF EN 10143/10346
 Revêtement: Z275 - NF EN 10346
 Chaque longueur de chemin de câbles est livrée avec 2 éclisses, pré-assemblées, une à chaque extrémité

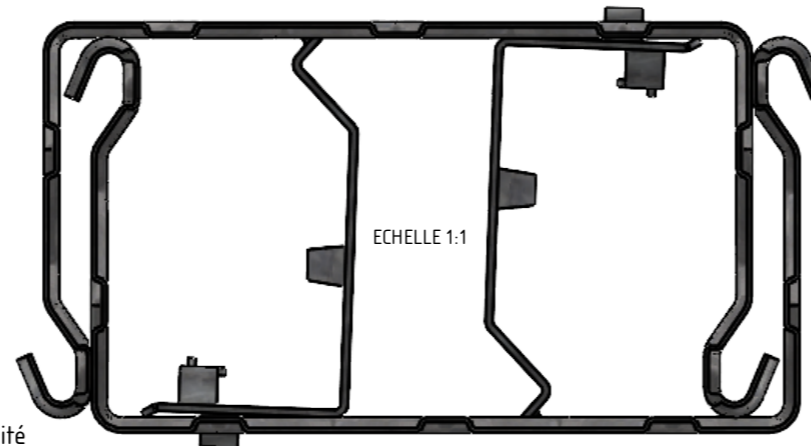
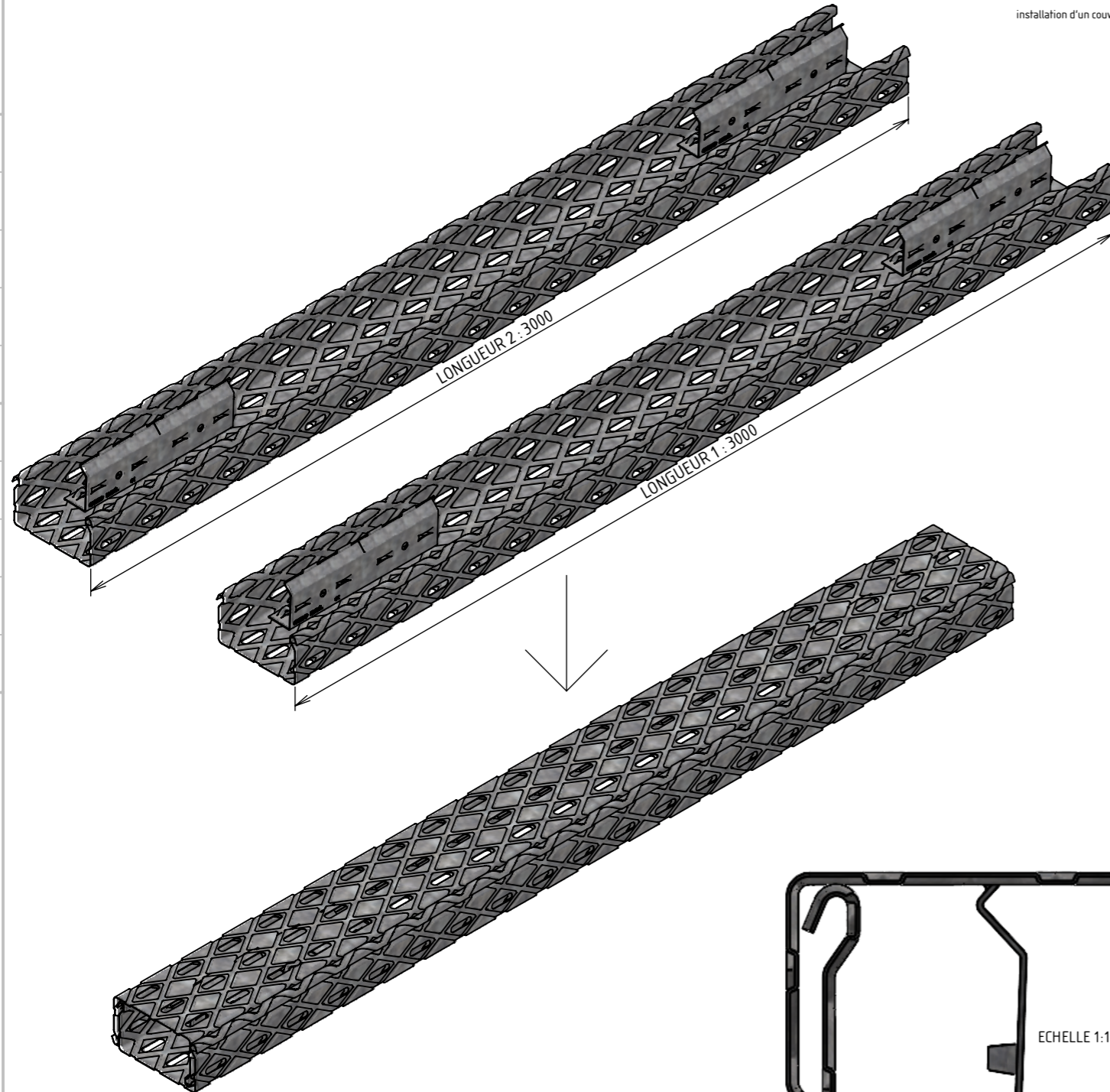

DESIGNATION:

CC 95 à 605 BRX50 PRET-A-POSER Z275

Propriété GEWISS France - Toute reproduction et utilisation tierce requièrent l'accord écrit de GEWISS France

Usine de Liernais
 BP 1
 21430 LIERNAIS
 TEL.: 03.80.90.51.00
 FAX: 03.80.84.43.66

DESSINE PAR:	BERGEROT D.	VERIFIE PAR:	LEGUY C.	FORMAT
DATE:	27/02/2023	ECHELLE:	1:5	A3 H
N°:	MVX0213GD à MVX0213GX			