

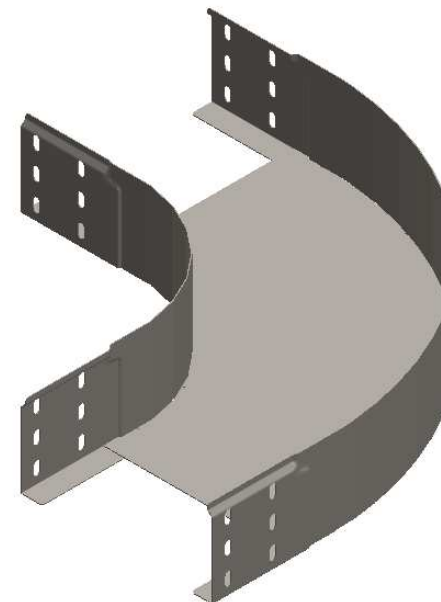

CODE	REF.	L (mm)	L1 (mm)	POIDS NET (Kg)	COLISAGE (NR)
MVG1120ND	95	368.4	93.8	1,280	10
MVG1120NF	155	428.4	153.8	1.732	10
MVG1120NH	215	488.4	213.8	1,954	8

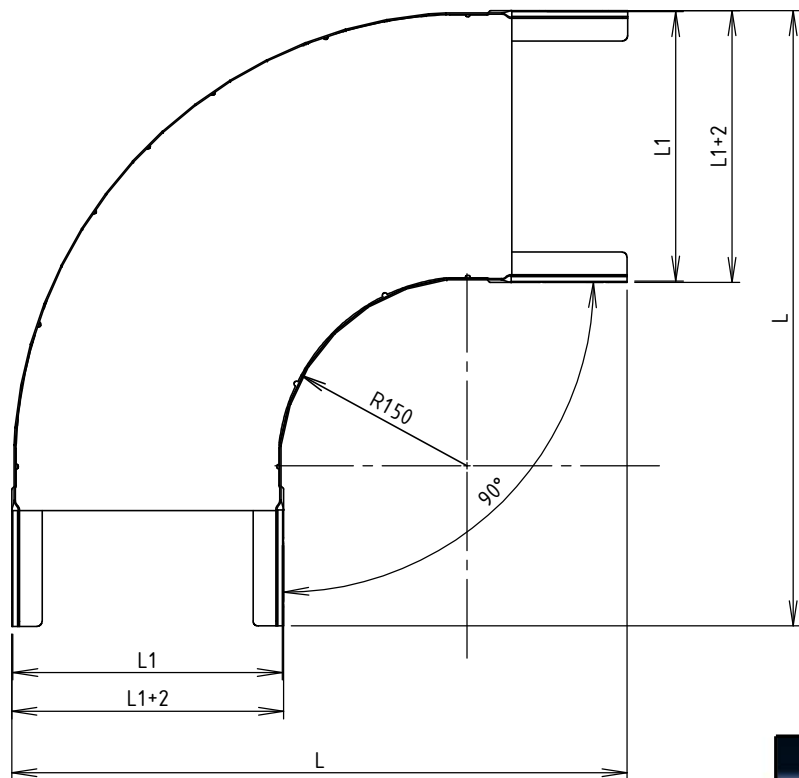

Matière cornière: BD REFENDUE 1,00 DC01 - NF EN 10130/10131
 Matière fond: FEUILLE 1,00 DC01 - NF EN 10130/10131
 Revêtement: GAC - Galvanisation à chaud par immersion selon NF EN 1461
 Dimensionnel garanti avant galvanisation

  Usine de Liernais BP 1 21430 LIERNAIS TEL.: 03.80.90.51.00 FAX: 03.80.84.43.66	DESIGNATION:				FORMAT A4 H
	COUDE 90° BRN95 NP R150 GAC				
	DESSINE PAR:	DOS SANTOS A.	VERIFIE PAR:	LEGUY C.	
	DATE:	14/02/2020	ECHELLE:	1:6	
N°:	MVG1120ND à MVG1120NH_01			