



Poids net: 0.502 Kg  
 Colisage: par 10 pièces  
 Matière: FEUILLE 2,50 DX51D Z275  
 Revêtement: Z275 - NF EN 10346  
 Couple admissible: 12 daN.m - NF EN 61537

|   |  |              |          |   |
|---|--|--------------|----------|---|
| <br> | DESIGNATION:   |              |          | TETE ORIENTABLE RAIL41-C40 Z275   |
|   | Usine de Liernais<br>BP 1<br>21430 LIERNAIS<br>TEL.: 03.80.90.51.00<br>FAX: 03.80.84.43.66 |              |          |   |
| DESSINE PAR:  | BERGEROT D.  | VERIFIE PAR: | LEGUY C. | FORMAT<br>A4 H  |
| DATE:   | 12/05/2015   | ECHELLE:     | 1:2      |   |
| N°:   | MV64155_01   |              |          |  |

## MONTAGE AVEC RAIL C40

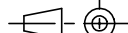
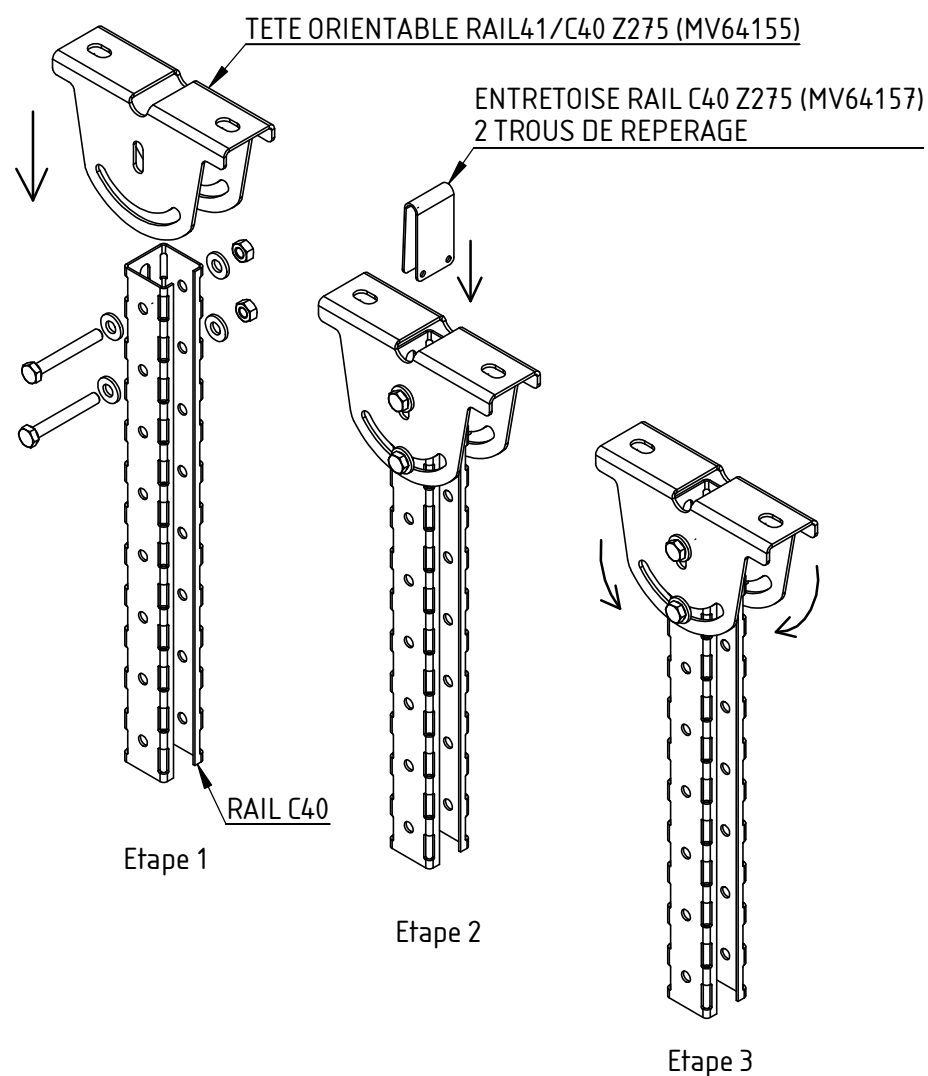

## MONTAGE AVEC RAIL 41

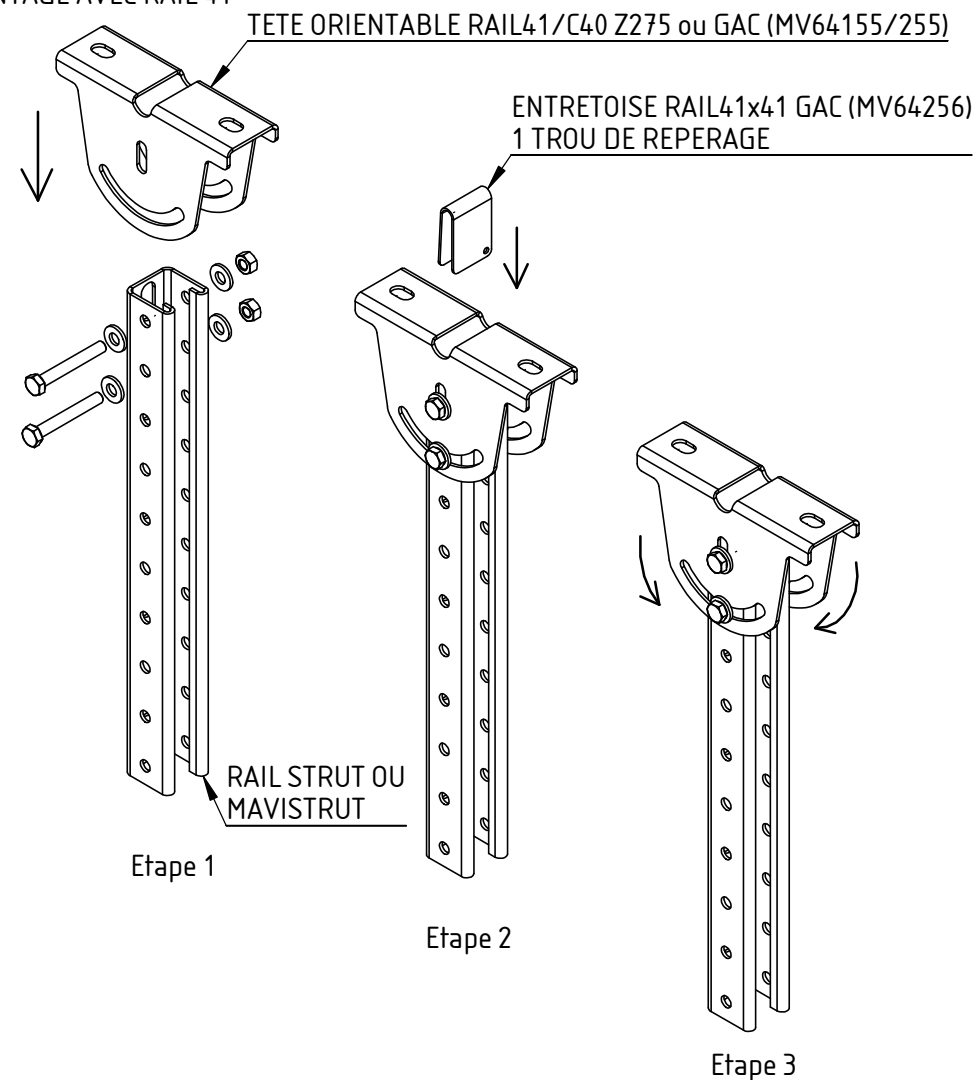

- 1: positionnement de la tête orientable sur le rail à l'aide des boulons HM8x60 + rondelles M 8 avec préserrage de ces derniers.
- 2: insertion l'entretoise adéquate dans le rail au travers de la tête.
- 3: mise en position et serrage des boulons au couple de 2.5 daN.m.

Usine de Liernais  
BP 1  
21430 LIERNAIS  
TEL.: 03.80.90.51.00  
FAX: 03.80.84.43.66

DESIGNATION:

MONTAGE TETE ORIENTABLE RAIL41-C40 Z275 ET GAC

|              |                    |              |          |                |
|--------------|--------------------|--------------|----------|----------------|
| DESSINE PAR: | GUENOT F.          | VERIFIE PAR: | LEGUY C. | FORMAT<br>A4 H |
| DATE:        | 19/06/2012         | ECHELLE:     | 1:5      |                |
| N°:          | MV64155 et MV64255 |              |          |                |