

CODE	L (mm)	POIDS NET (Kg)	CHARGE ADMISSIBLE (daN.m)	COLISAGE (pièce)
MV63755	400	1.072	20	20
MV63751	500	1.212	20	20
MV63756	600	1.351	18	10
MV63757	800	1.633	18	1
MV63752	1000	1.913	14.5	1
MV63758	1500	2.615	Non communiqué ou sur demande	1

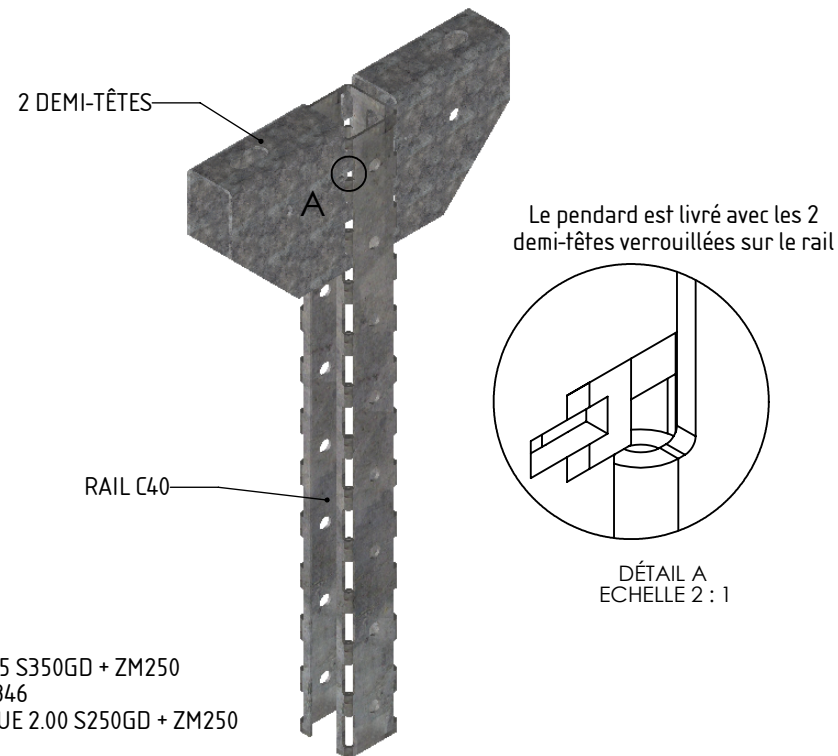

Matière rail: BANDE REFENDUE 1.75 S350GD + ZM250
 Revêtement rail: ZM250 - NF EN 10346
 Matière demi-tête: BANDE REFENDUE 2.00 S250GD + ZM250
 Revêtement: ZM250 - NF EN 10346

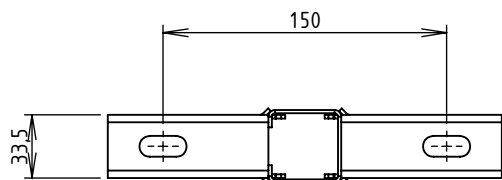

DESIGNATION:

PENDARD C40 HP

Usine de Liernais
 BP 1
 21430 LIERNAIS
 TEL.: 03.80.90.51.00
 FAX: 03.80.84.43.66

DESSINE PAR:	BOUCHET S.	VERIFIE PAR:	LEGUY C.	FORMAT A4 H
DATE:	07/09/2015	ECHELLE:	1:4	
N°:	MV63751 à MV63758			