

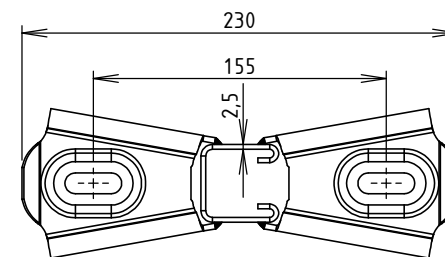

CODE	L (mm)	COLISAGE (NR)	POIDS NET (Kg)
MV80212	310	14	1.514
MV80213	390	14	1.727
MV80214	470	12	1.939
MV80215	550	10	2.151
MV80216	630	10	2.364
MV80217	710	10	2.576
MV80218	790	6	2.789
MV80219	870	6	3.001
MV80220	950	6	3.213
MV80221	1030	6	3.426
MV80222	1110	6	3.638
MV80223	1190	2	3.851
MV80224	1270	2	4.063
MV80225	1350	2	4.275
MV80226	1430	2	4.488
MV80227	1510	2	4.700
MV80228	1590	2	4.913
MV80229	1670	2	5.125
MV80230	1750	2	5.337
MV80231	1830	2	5.550
MV80232	1910	2	5.762
MV80233	1990	2	5.975

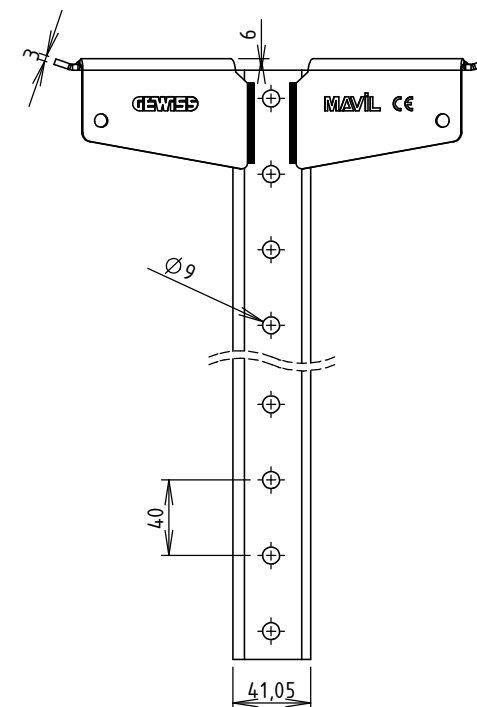
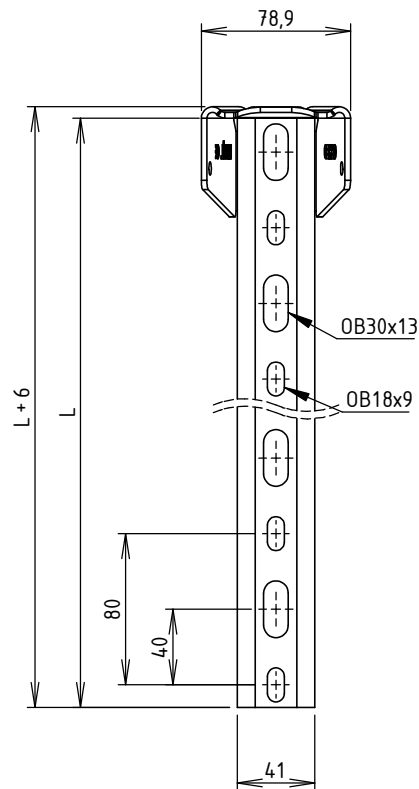

Matière profil: BANDE REFENDUE 2.50 S235 JR
 Matière demi-tête: BANDE REFENDUE 3.00 S235 JR
 Revêtement: GAC - NF EN ISO 1461

	DESIGNATION:			PENDARD STRUT 41x41S GAC
	Usine de Liernais BP 1 21430 LIERNAIS TEL.: 03.80.90.51.00 FAX: 03.80.84.43.66	DESSINE PAR: BERGEROT D.	VERIFIE PAR: LEGUY C.	
	DATE: 20/07/2017	ECHELLE: 1:4		
	N°:	MV80212 à MV80233_02		

