

ECLISSE AUTO BFR ECO Ø4.5 HP		CC BFR60 HP						CC BFR60 PRE-ECLISSE HP				
CODE	POIDS NET (Kg)	CODE	L (mm)	H (mm)	A (mm)	POIDS NET (Kg)	CPS portée 1.5/2.0/2.5 m (daN/m)	CODE	L (mm)	POIDS NET (Kg)	COLISAGE	
											CC BFR60 (m)	ECLISSE (NR)
MV51714	0.073	MV50734	250	75.4	23.4	4.585	36/29/20	MV50784	250	4.731	6	4
		MV50735	300			5.568						

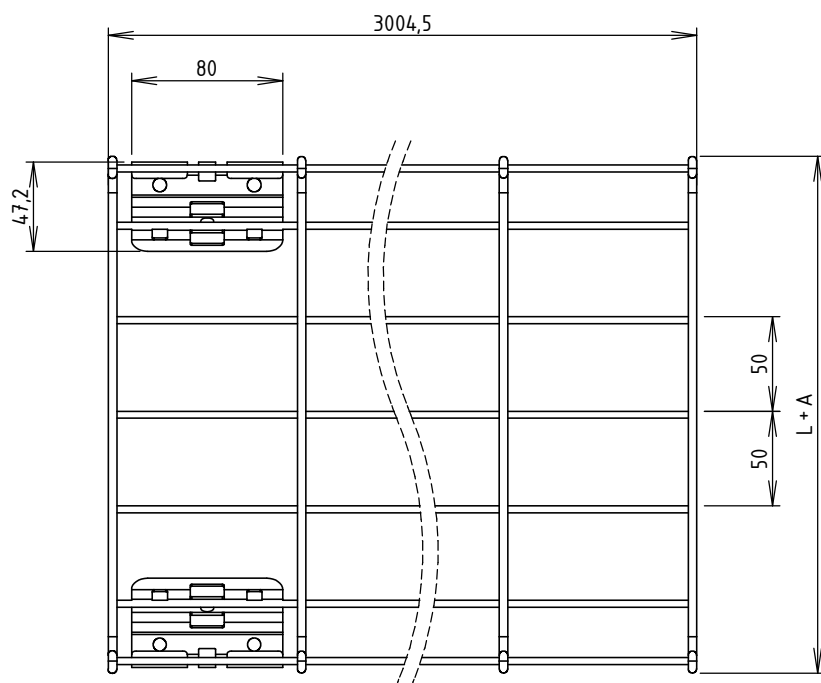

CC BFR60 HP (MV50734 à MV50735)

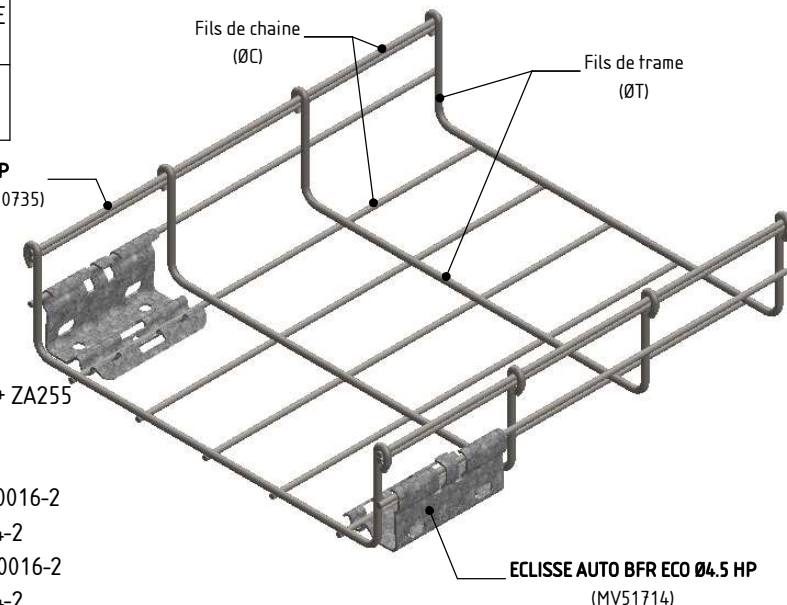

**ECLISSE AUTO BFR ECO Ø4.5 HP:**  
 Matière: BANDE REFENDUE 1.25 S350GD + ZA255  
 Revêtement: ZA255 - NF EN 10346

**CC BFR60 HP:**  
 Matière: FIL Ø3.7 C9D CRAPAL 4 - NF EN 10016-2  
 Revêtement: ZA275 CLASSE A - NF EN 10244-2  
 : FIL Ø4.5 C9D CRAPAL 4 - NF EN 10016-2  
 Revêtement: ZA280 CLASSE A - NF EN 10244-2

**CPS (Charge Pratique de Sécurité selon NF EN 61537)**

	DESIGNATION:		CC BFR60 PRE-ECLISSE HP	
	Usine de Liernais BP 1 21430 LIERNAIS TEL.: 03.80.90.51.00 FAX: 03.80.84.43.66	DESSINE PAR: BERGEROT D.	VERIFIE PAR: LEGUY C.	FORMAT A4 H
	DATE: 16/09/2016	ECHELLE: 1:4		
	N°:	MV50784 à MV50785_02		

