

DÉTAIL C  
ECHELLE 1 : 4

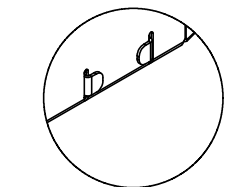

DÉTAIL B  
ECHELLE 1 : 4

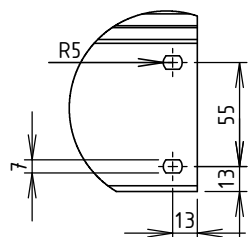

COUPE A-A  
ECHELLE 1 : 4

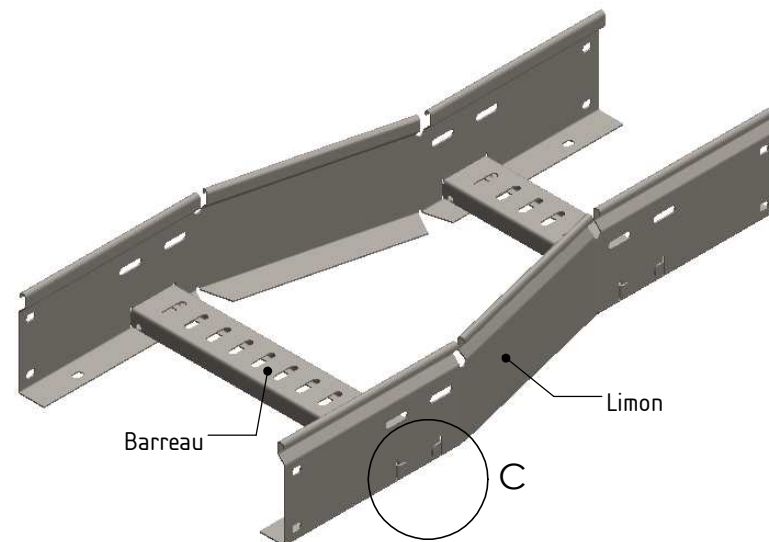
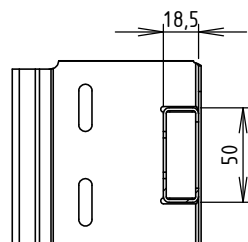

Matière: TÔLE NOIRE 1.50 S235JR  
Revêtement: GAC - NF EN ISO 1461

CODE	L1 (mm)	L2 (mm)	Poids (kg)
MV98212	100	200	
MV98213	200	300	
MV98214	300	400	
MV98215	400	500	
MV98216	500	600	

**GEWISS**

**MAVIL**

Usine de Liernais  
BP 1  
21430 LIERNAIS  
TEL.: 03.80.90.51.00  
FAX: 03.80.84.43.66

DESIGNATION:

REDUCTION CENT EAC ML100 GAC

DESSINE PAR:	BONIN G.	VERIFIE PAR:	BERGEROT D.	FORMAT A4 H
DATE:	03/11/2015	ECHELLE:	1:6	
N°:	MV98212 à MV98216			