

ECLISSE AUTO BFR ECO Ø4.5 Z275

CC BFR60 Z100

CC BFR60 PRE-ECLISSE Z100

CODE	POIDS NET (Kg)	CODE	L (mm)	H (mm)	A (mm)	POIDS NET (Kg)	CPS portée 1.5/2.0/2.5 m (daN/m)	CODE	L (mm)	POIDS NET (Kg)	COLISAGE	
											CC BFR60 (m)	ECLISSE (NR)
MV51114	0.085	MV50534	250	75.4	23.4	4.486	36/29/20	MV50584	250	4.656	6	4
		MV50535	300			5.447						

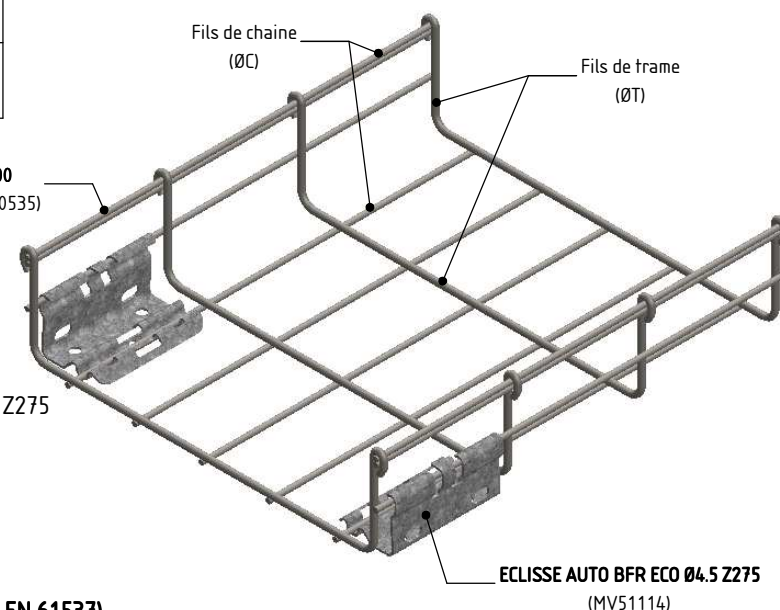
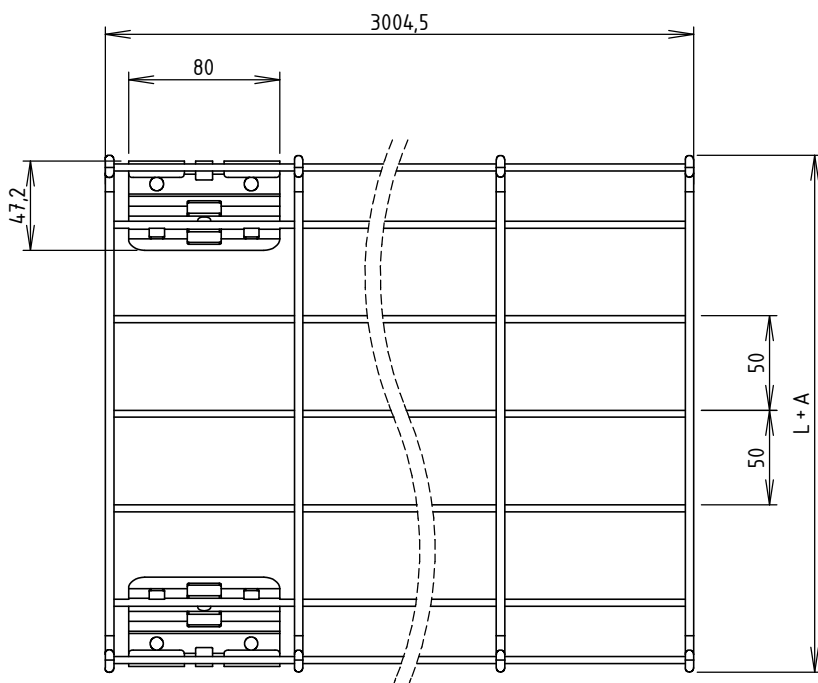

ECLISSE AUTO BFR ECO Ø4.5 Z275:

Matière: BANDE REFENDUE 1.50 S350GD + Z275

Revêtement: Z275 - NF EN 10346



CC BFR60 Z100:

Matière: FIL Ø3.7 C9D - NF EN 16120-2

: FIL Ø4.5 C9D - NF EN 16120-2

Revêtement: Z100 - NF EN 10244-2

CPS (Charge Pratique de Sécurité selon NF EN 61537)

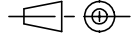
  Usine de Liernais BP 1 21430 LIERNAIS TEL.: 03.80.90.51.00 FAX: 03.80.84.43.66	DESIGNATION:		CC BFR60 PRE-ECLISSE Z100	
	DESSINE PAR:	BERGEROT D.	VERIFIE PAR:	LEGUY C.
	DATE:	15/09/2016	ECHELLE:	1:4
	N°:	MV50584 à MV50585_02		

FORMAT A4 H