

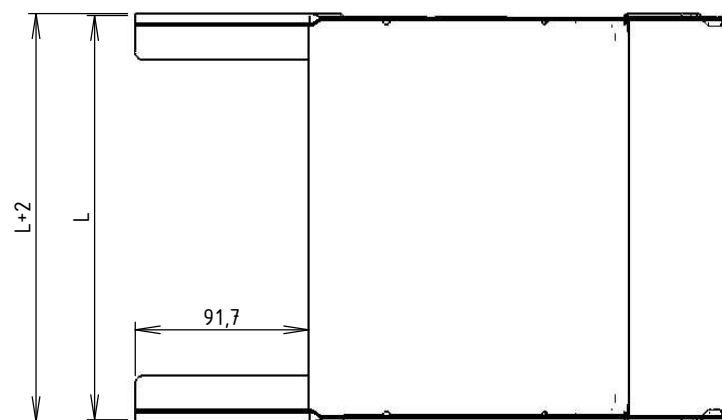

| CODE | REF. | L (mm) | POIDS NET (Kg) |
|-----------|------|--------|----------------|
| MVG1910GC | 65 | 63.8 | 0,684 |
| MVG1910GD | 95 | 93.8 | 0,744 |
| MVG1910GF | 155 | 153.8 | 0,864 |
| MVG1910GH | 215 | 213.8 | 0,984 |

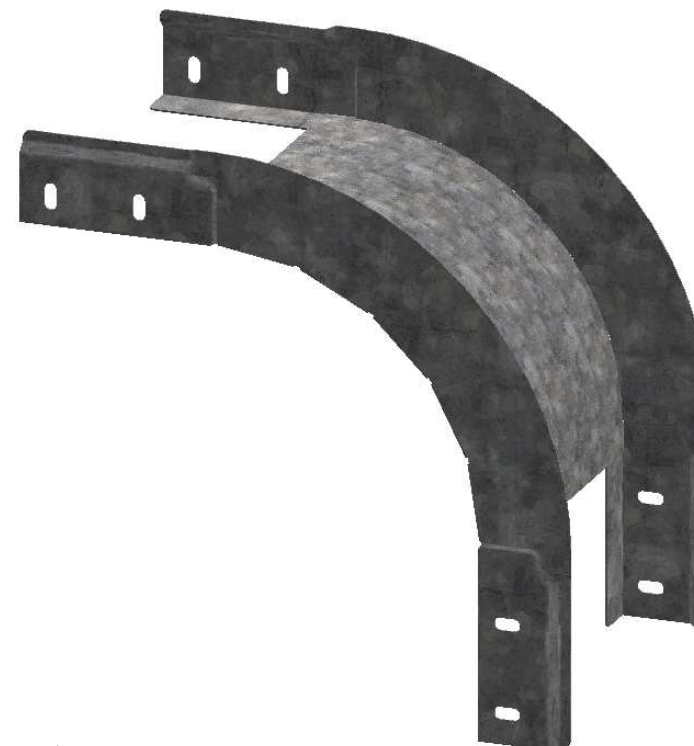
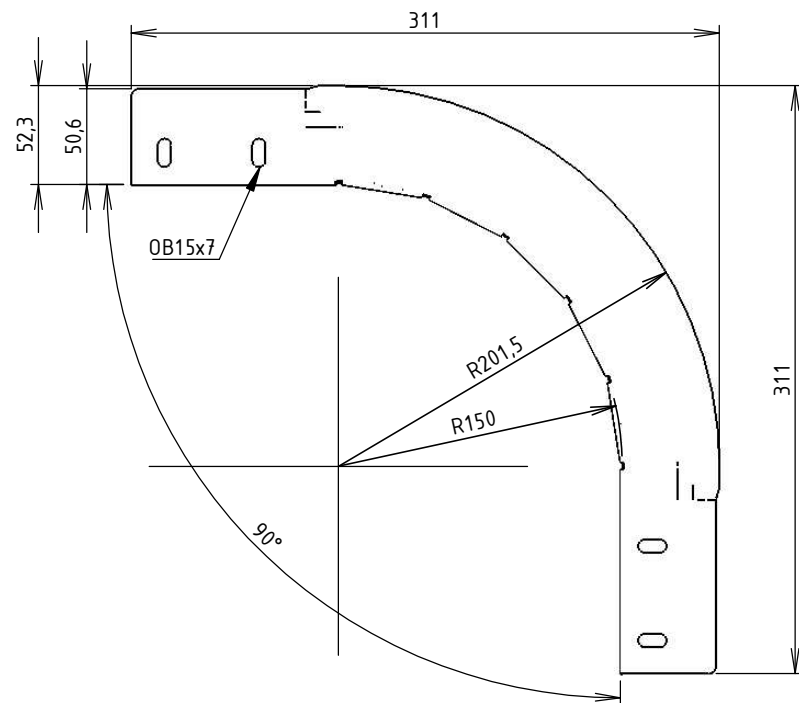

Colisage : 2 pièces
 Assemblage réalisé par clinchage
 Matière cornière: FEUILLE 1,00 DX51D + Z275 - NF EN 10143/10346
 Matière fond: FEUILLE 0,90 DX51D + Z275 - NF EN 10143/10346
 Revêtement: Z275 - NF EN 10346

| | | | | |
|---|--------------------------------------|-----------------------|---|----------------|
|   Usine de Liernais BP 1 21430 LIERNAIS TEL.: 03.80.90.51.00 FAX: 03.80.84.43.66 | DESIGNATION: | | | FORMAT A4 H |
| | COUDE CONVEXE 90° BRN50 NP R150 Z275 | | | |
| | DESSINE PAR: DOS SANTOS A. | VERIFIE PAR: LEGUY C. | | |
| | DATE: 12/02/2020 | ECHELLE: 1:4 | | |
| N°: | MVG1910GC à MVG1910GH_01 | |  | |

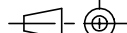
Propriété GEWISS France - Toute reproduction et utilisation tierce requièrent l'accord écrit de GEWISS France