

Colisage: 6 m
 Poids net: 5.471 Kg
 Matière: FIL Ø4.5 C9D CRAPAL 4 - NF EN 10016-2
 Revêtement: ZA280 CLASSE A - NF EN 10244-2
 CPS: Charge pratique de sécurité - NF EN 61537
 28.1 daN/m: portée 1.5m
 17.9 daN/m: portée 2.0m
 11.8 daN/m: portée 2.5m



Usine de Liernais
 BP 1
 21430 LIERNAIS
 TEL.: 03.80.90.51.00
 FAX: 03.80.84.43.66

DESIGNATION:

CC 300 BFR30 HP

Propriété GEWISS France - Toute reproduction et utilisation tierce requièrent l'accord écrit de GEWISS France

DESSINE PAR:	BERGEROT D.	VERIFIE PAR:	LEGUY C.	FORMAT A4 H
DATE:	15/07/2020	ECHELLE:	1:4	
N°:	MV50725_05			

CODE	REF.	POIDS NET (Kg)	POIDS NET (Kg/m)	vx (mm)	vy (mm)	S (mm ²)	lxx (mm ⁴)	lyy (mm ⁴)	lxx/vx (mm ³)	lyy/vy (mm ³)	RAYON DE GIRATION R (mm)
MV50725	300 BFR30	5.471	1.824	23.318	158	159.043	36344.776	2138314.055	1558.65	13533.63	159.418

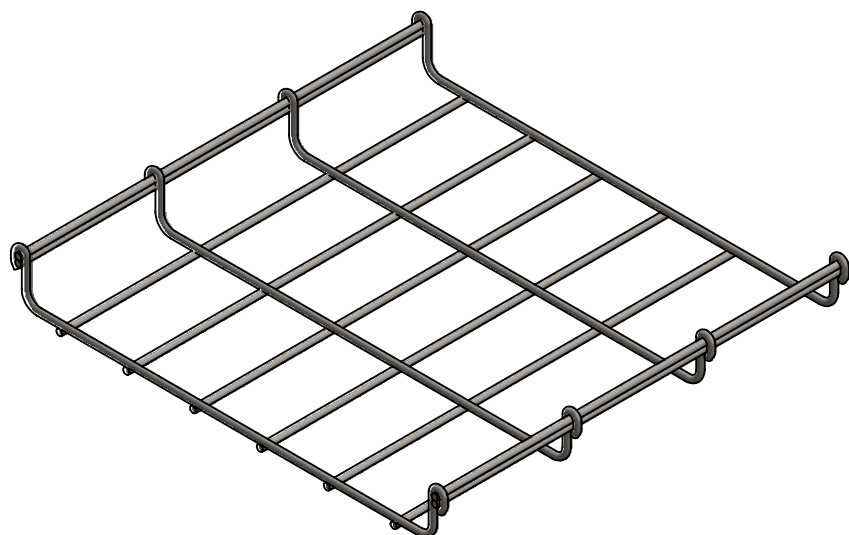
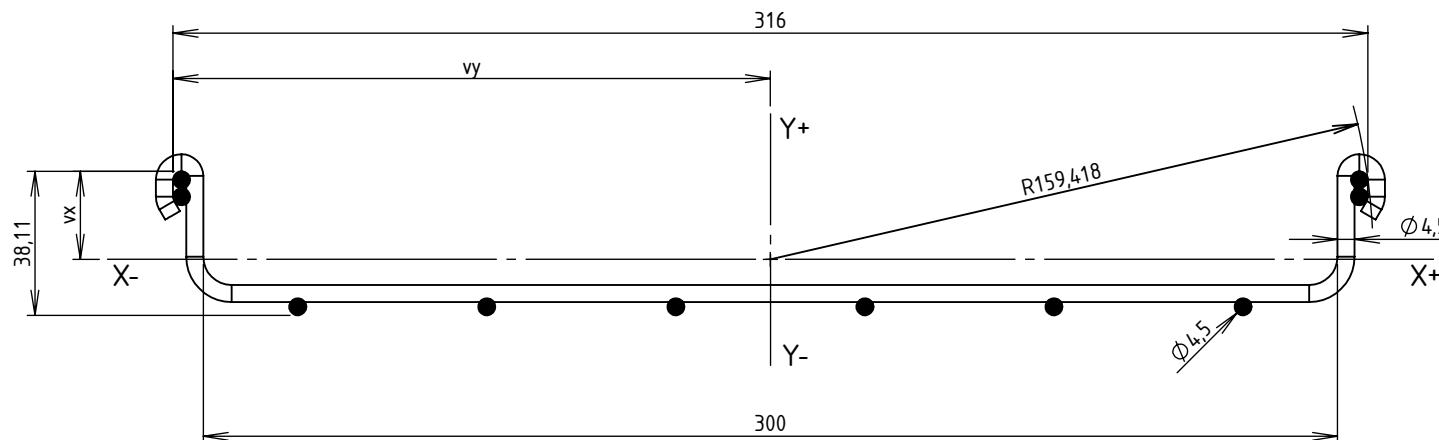

Matière: FIL Ø4.5 C9D CRAPAL 4 - NF EN 10016-2
 Revêtement: ZA280 CLASSE A - NF EN 10244-2



Usine de Liernais
 BP 1
 21430 LIERNAIS
 TEL.: 03.80.90.51.00
 FAX: 03.80.84.43.66

DESIGNATION: CC 300 BFR30 HP
 INERTIE
Propriété GEWISS France - Toute reproduction et utilisation tierce requièrent l'accord écrit de GEWISS France

DESSINE PAR:	BERGEROT D.	VERIFIE PAR:	LEGUY C.	FORMAT A4 H
DATE:	15/07/2020	ECHELLE:	1:2	
N°:	MV50725_05			

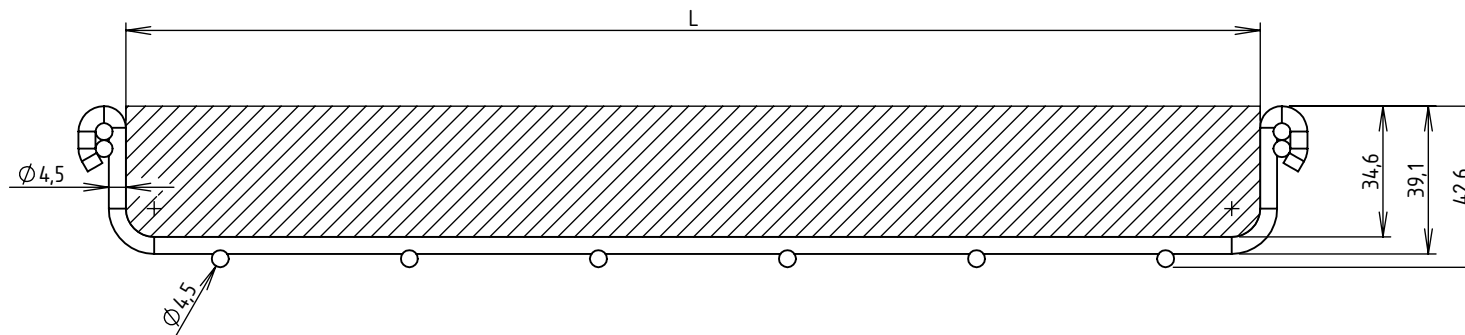

CODE	L (mm)	SECTION UTILE (mm ²)	CONTENANCE (Kg/m)	
			Communication (d = 0.15 Kg/cm ² /m)	Puissance (d = 0.25 Kg/cm ² /m)
MV50X25	300	10360	15.54	25.90



Usine de Liernais
BP 1
21430 LIERNAIS
TEL.: 03.80.90.51.00
FAX: 03.80.84.43.66

DESIGNATION:

SECTIONS UTILES ET CONTENANCES BFR30
CC 300 BFR30

Propriété GEWISS France - Toute reproduction et utilisation tierce requièrent l'accord écrit de GEWISS France

DESSINE PAR:	BERGEROT D.	VERIFIE PAR:	LEGUY C.	FORMAT A4 H
DATE:	05/06/2024	ECHELLE:	1:2	
N°:	MV50X25			