

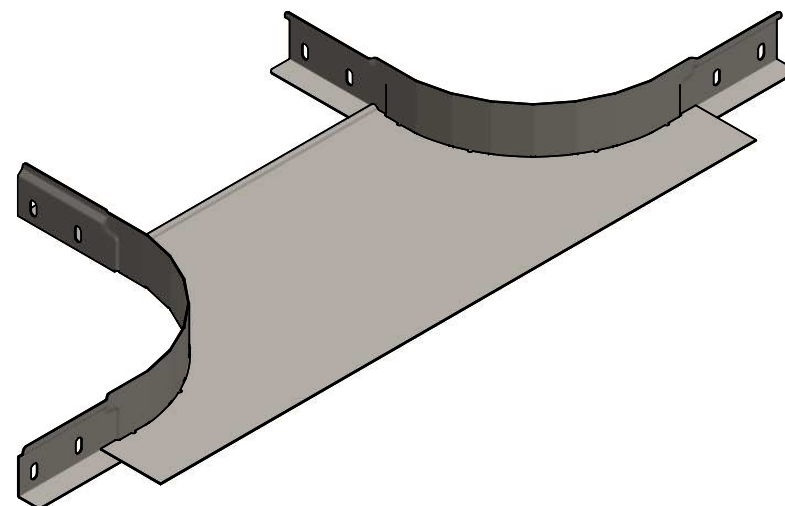

CODE	REF.	L (mm)	L1 (mm)	L2 (mm)	SURFACE (mm ²)	POIDS NET (Kg)	COLISAGE (NR)
MVG1420GL	305	850.8	303.8	341.4	363276	1.523	10
MVG1420GP	395	940.8	393.8	341.4	408728	1.716	10
MVG1420GU	515	1086.8	513.8	354.4	491301	2.065	8
MVG1420GX	605	1150.8	603.8	341.4	514783	2.164	8

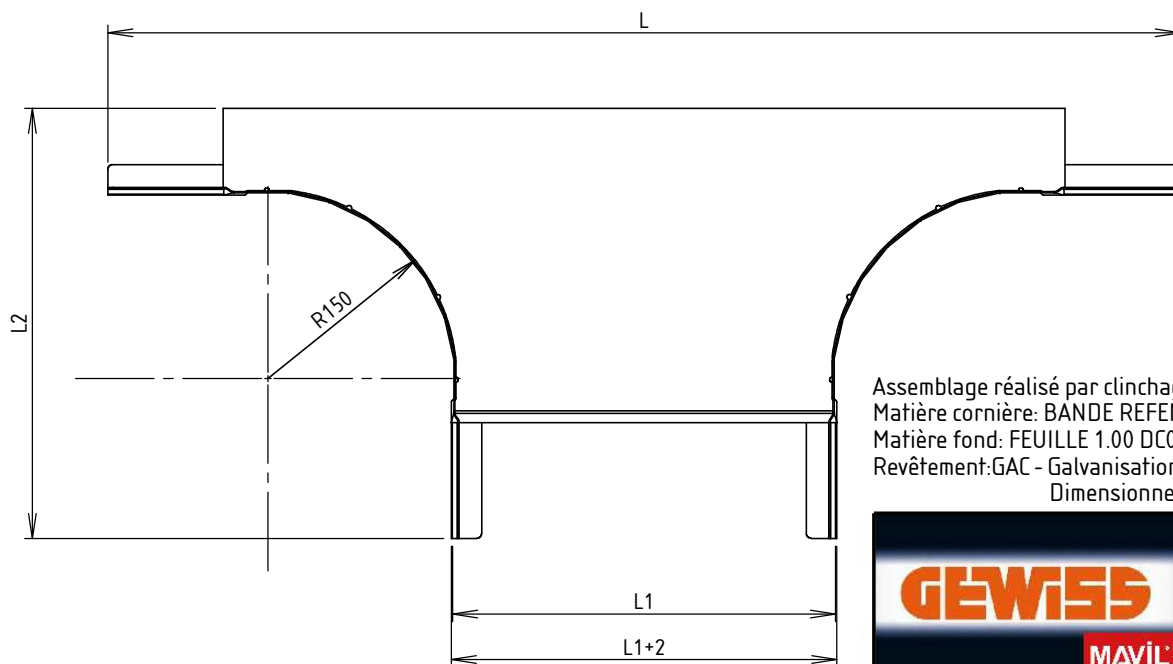
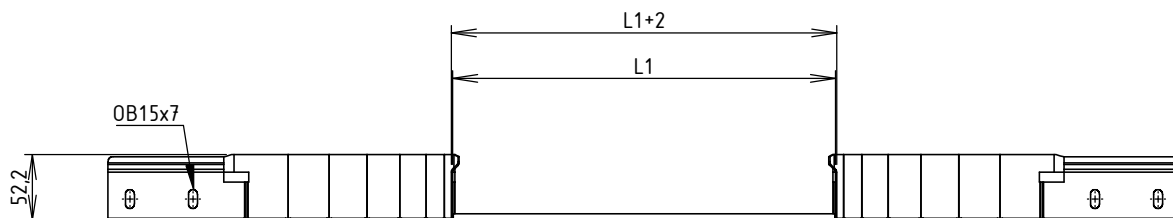

Assemblage réalisé par clinchage
 Matière cornière: BANDE REFENDUE 1,00 DC01 - NF EN 10130 / 10131
 Matière fond: FEUILLE 1.00 DC01 - NF EN 10130 / 10131
 Revêtement: GAC - Galvanisation à chaud par immersion selon NF EN 1461
 Dimensionnel garanti avant galvanisation

 	DESIGNATION:			SORTIE LATERAL BRN50 NP R150 GAC	
	Propriété GEWISS France - Toute reproduction et utilisation tierce requièrent l'accord écrit de GEWISS France				
Usine de Liernais BP 1 21430 LIERNAIS TEL.: 03.80.90.51.00 FAX: 03.80.84.43.66	DESSINE PAR:	BERGEROT D.	VERIFIE PAR:	LEGUY C.	FORMAT A4 H
	DATE:	13/05/2019	ECHELLE:	1:6	
	N°:	MVG1420GL à MVG1420GX_01			