

PLIAGE 30mm

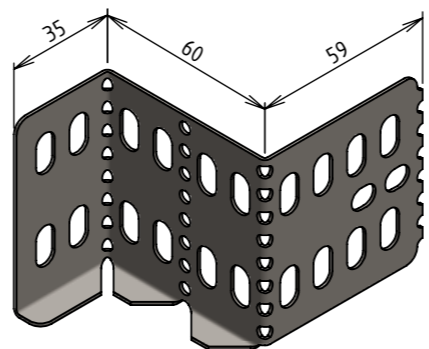

PLIAGE 60mm

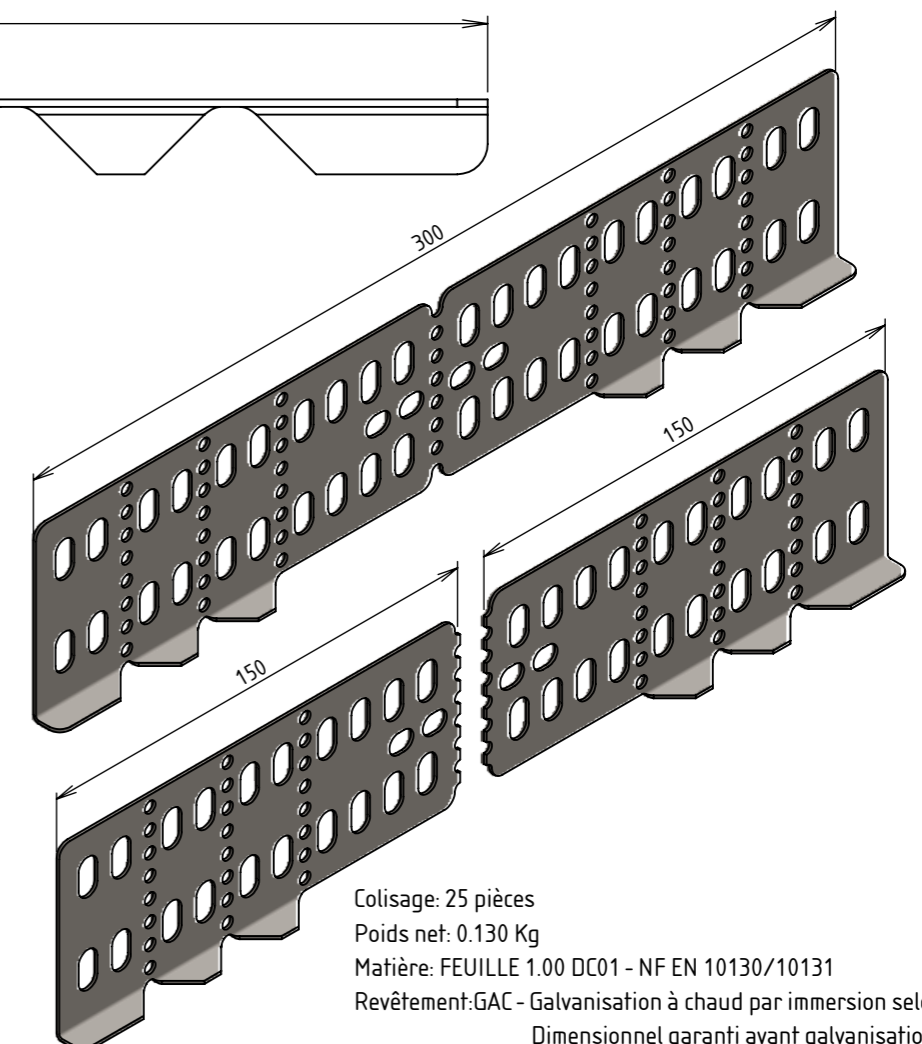

Colisage: 25 pièces  
 Poids net: 0.130 Kg  
 Matière: FEUILLE 1.00 DC01 - NF EN 10130/10131  
 Revêtement: GAC - Galvanisation à chaud par immersion selon NF EN 1461  
 Dimensionnel garanti avant galvanisation

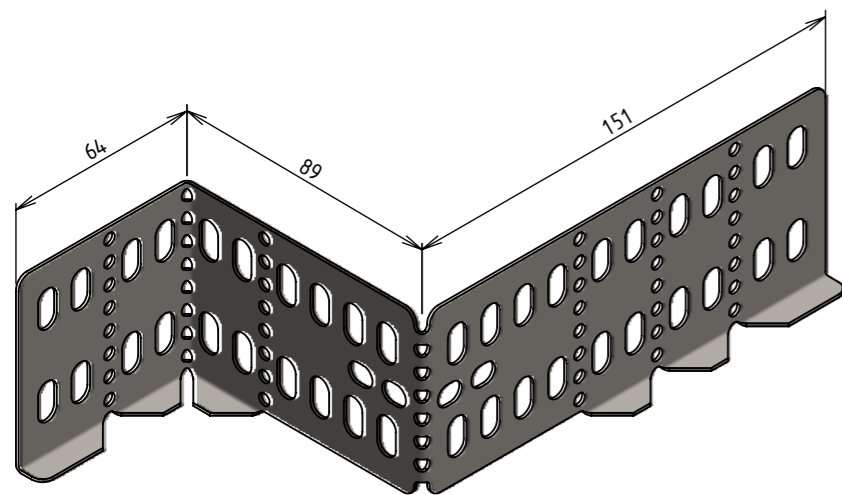

PLIAGE 90mm

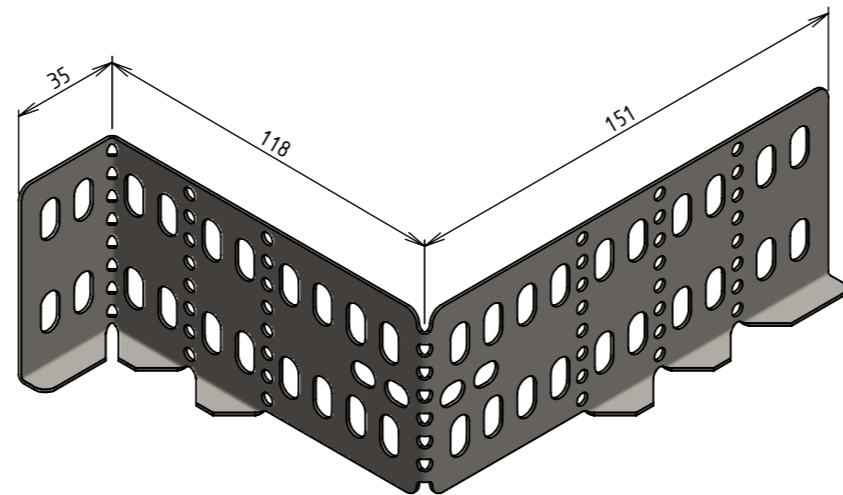

PLIAGE 120mm



DESIGNATION: ECLISSE D'ANGLE UNIV BRN80 GAC

Propriété GEWISS France - Toute reproduction et utilisation tierce requièrent l'accord écrit de GEWISS France

DESSINE PAR: BERGEROT D.	VERIFIE PAR: LEGUY C.	FORMAT: A3 H
DATE: 28/08/2023	ECHELLE: 1:1	
N°:	MVC3520LA_02	

Usine de Liernais  
 BP 1  
 21430 LIERNAIS  
 TEL.: 03.80.90.51.00  
 FAX: 03.80.84.43.66

REDUCTIONS: PLIAGE 30 mm

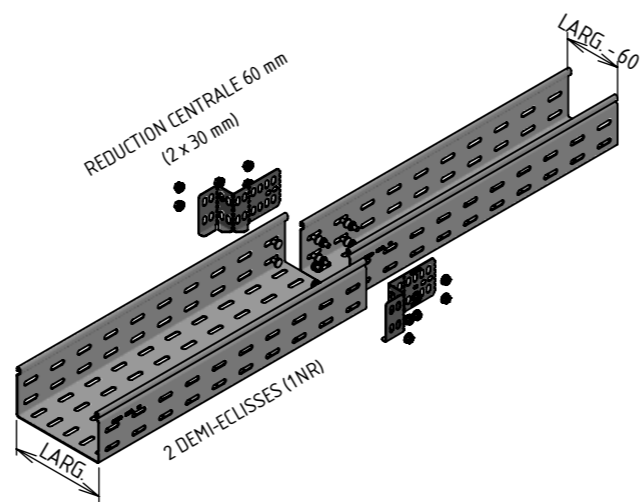
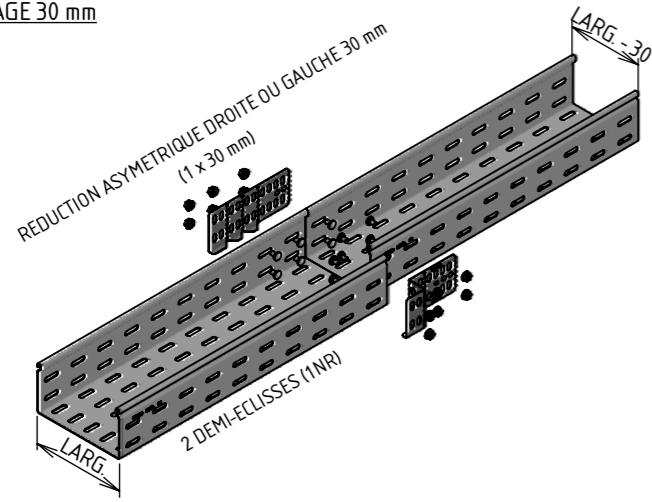

REDUCTIONS: PLIAGE 60 mm

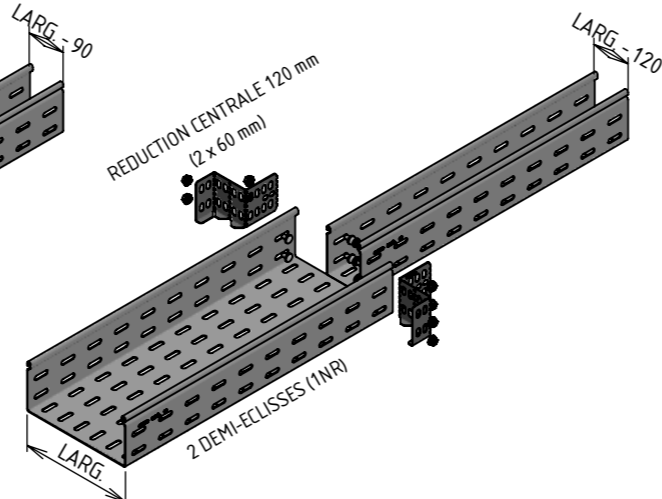
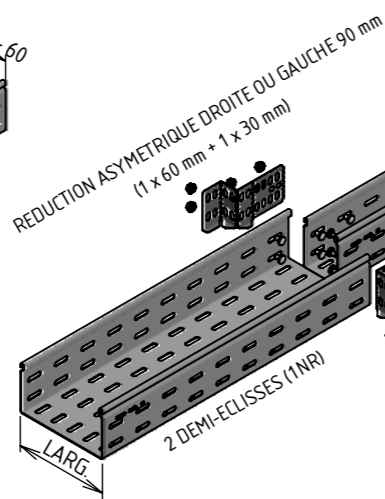
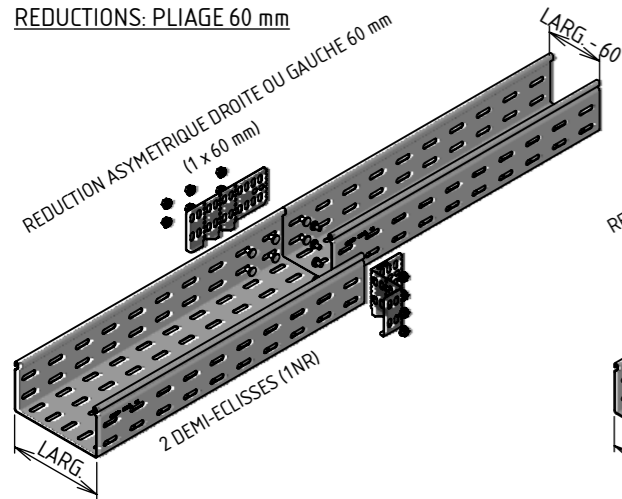

REDUCTIONS: PLIAGE 90 mm

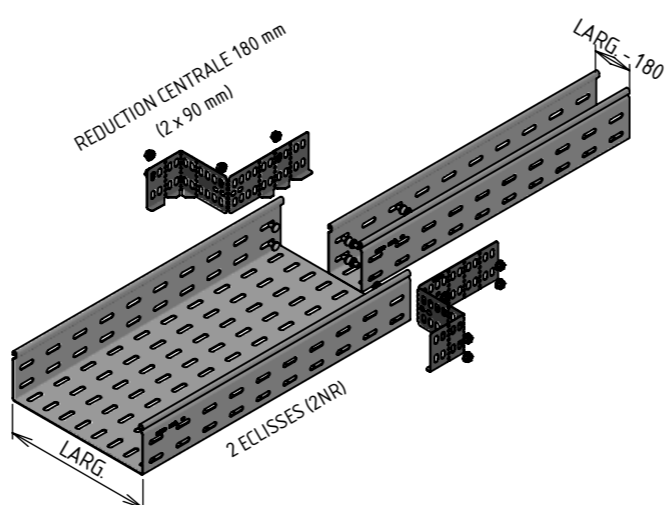
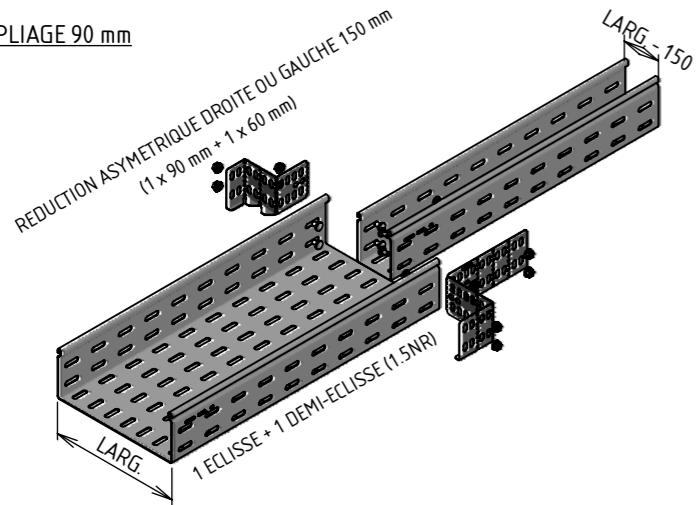

REDUCTIONS: PLIAGE 120 mm

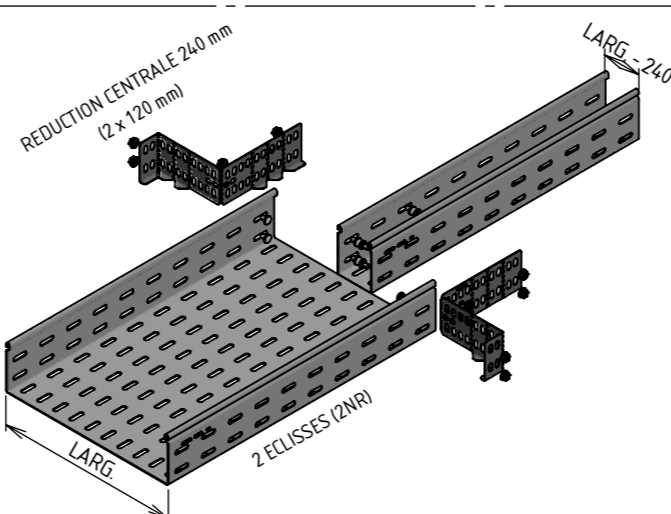
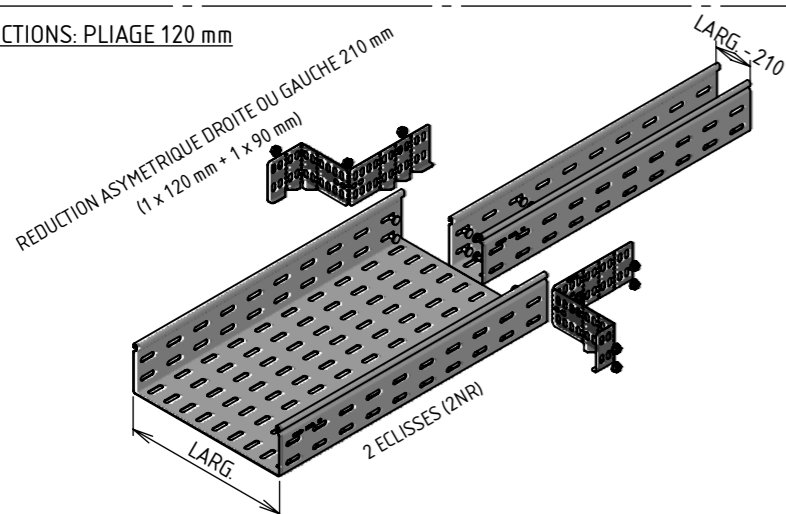

ECLISSE

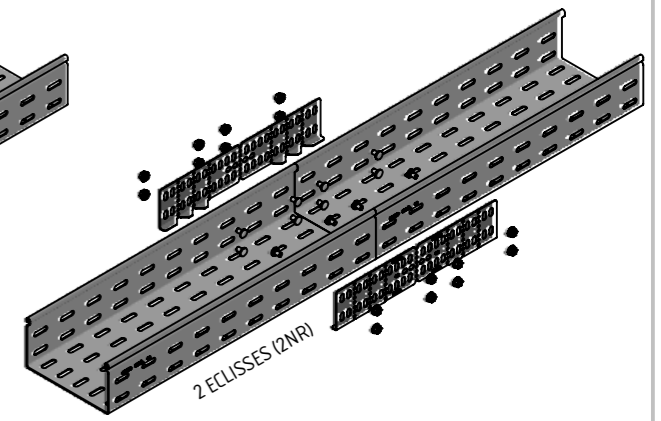
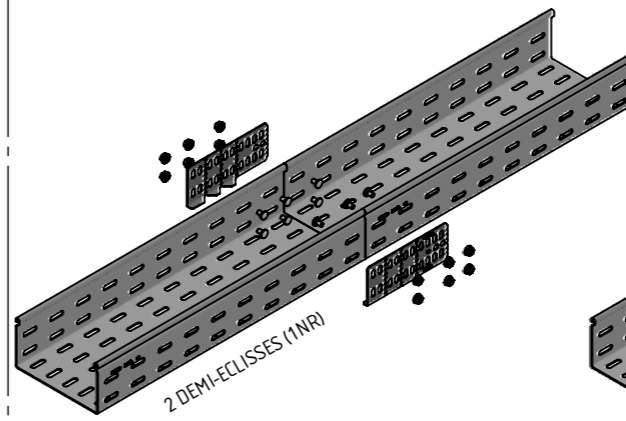

ECLISSE PLIABLE  
PLAGE DE PLIAGE: 0° à 90°

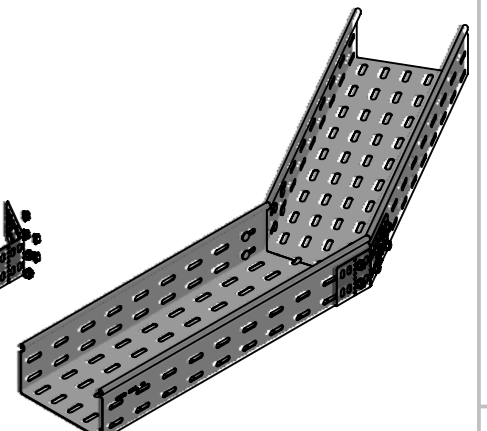
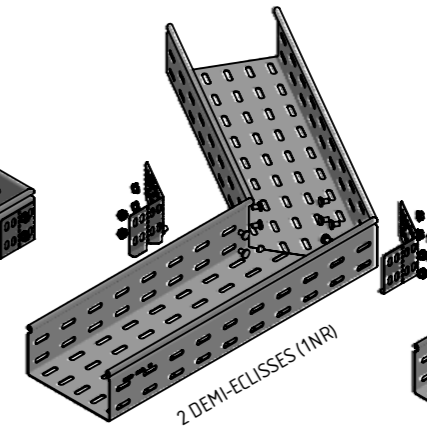
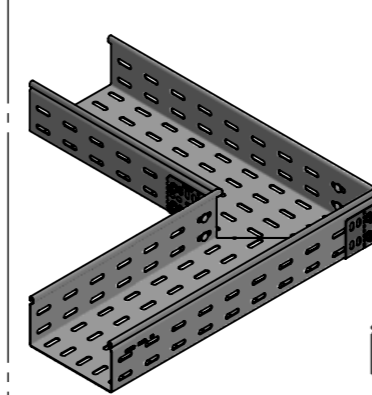

ECLISSE ARTICULEE

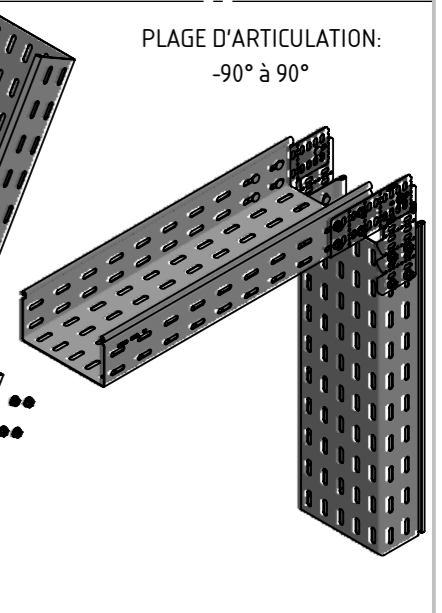
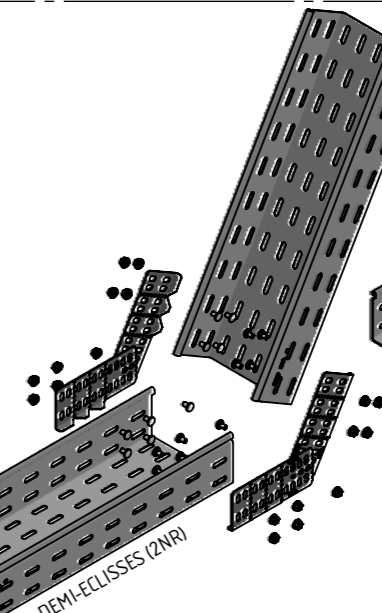
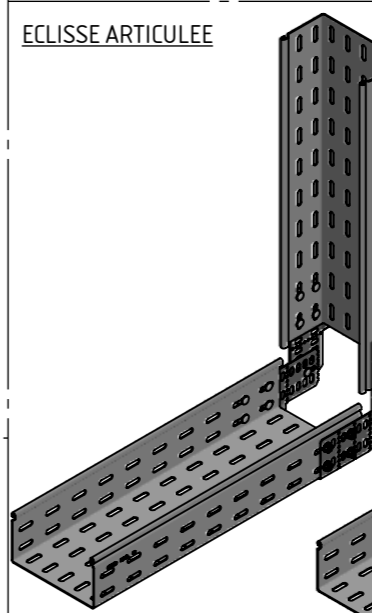

DESIGNATION:

ECLISSE D'ANGLE UNIV BRN80

Propriété GEWISS France - Toute reproduction et utilisation tierce requièrent l'accord écrit de GEWISS France

Usine de Liernais  
BP 1  
21430 LIERNAIS  
TEL.: 03.80.90.51.00  
FAX: 03.80.84.43.66

DESSINE PAR:	BERGEROT D.	VERIFIE PAR:	LEGUY C.	FORMAT
DATE:	28/08/2023	ECHELLE:	1:10	A3 H
N°:	MVC3510LA et MVC3520LA et MVC3570LA			