

**ECLISSE AUTO BFR ECO Ø4.5 INOX 316L**

**CC BFR60 INOX 316L**

**CC BFR60 PRE-ECLISSE INOX 316L**

CODE	POIDS NET (Kg)	CODE	L (mm)	H (mm)	A (mm)	POIDS NET (Kg)	CPS portée 1.5/2.0/2.5 m (daN/m)	CODE	L (mm)	POIDS NET (Kg)	COLISAGE	
											CC BFR60 (m)	ECLISSE (NR)
MV51814	0.085	MV50834	250	75.4	23.4	4.513	36/29/20	MV50884	250	4.683	6	4
		MV50835	300			5.480						

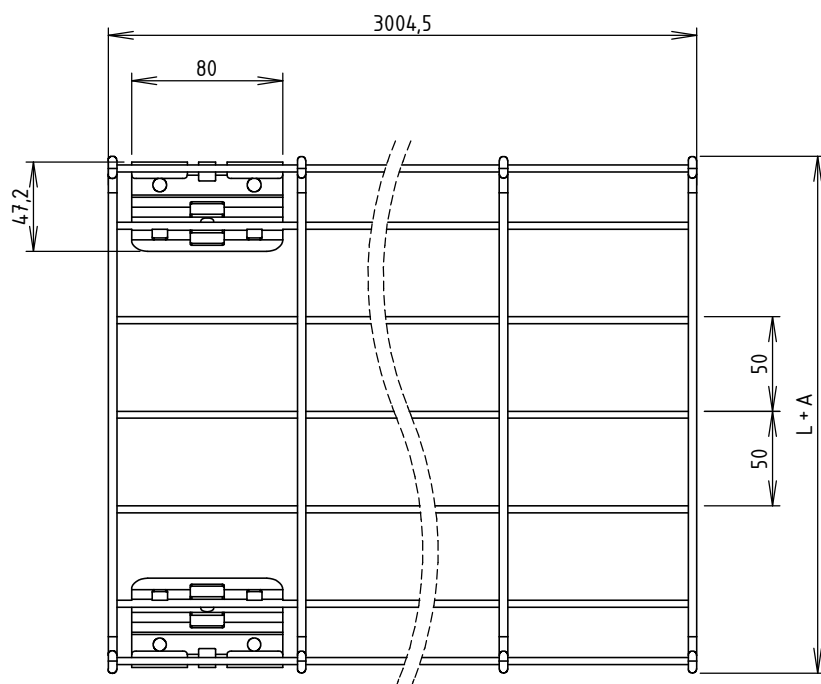

**CC BFR60 INOX 316L**  
(MV50834 à MV50835)

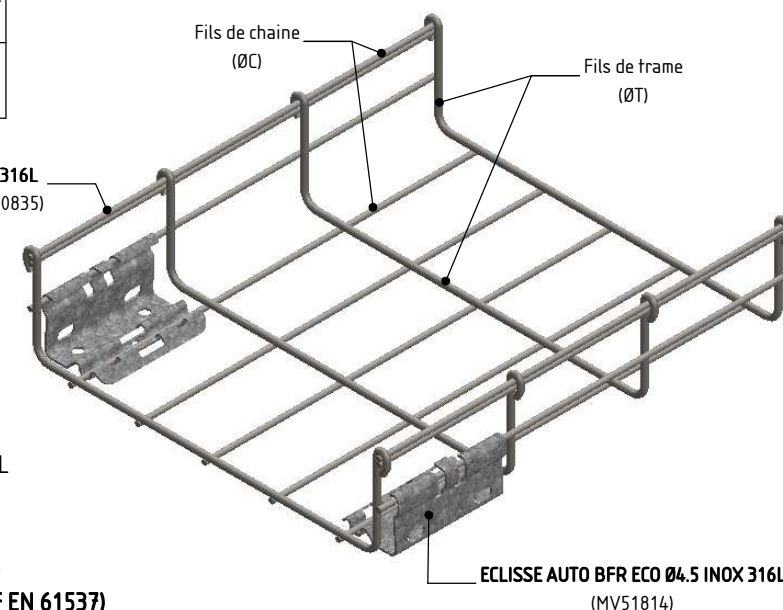

**ECLISSE AUTO BFR ECO Ø4.5 INOX 316L:**

Matière: BANDE REFENDUE 1.50 INOX 316L

**CC BFR60 INOX 316L:**

Matière: FIL Ø3.7 INOX 316L - NF EN 10088

: FIL Ø4.5 INOX 316L - NF EN 10088

**CPS (Charge Pratique de Sécurité selon NF EN 61537)**

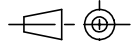
 Usine de Liernais BP 1 21430 LIERNAIS TEL.: 03.80.90.51.00 FAX: 03.80.84.43.66	DESIGNATION:		CC BFR60 PRE-ECLISSE INOX 316L	
	DESSINE PAR:	BERGEROT D.	VERIFIE PAR:	LEGUY C.
	DATE:	16/09/2016	ECHELLE:	1:4
	N°:	MV50884 à MV50885_02		

FORMAT  
A4 H