

ECLISSE AUTO BFR ECO Ø4.9 HP		CC BFR60 HP							CC BFR60 PRE-ECLISSE HP				
CODE	POIDS NET (Kg)	CODE	L (mm)	H (mm)	ØC (mm)	A (mm)	POIDS NET (Kg)	CPS portée 1.5/2.0/2.5 m (daN/m)	CODE	L (mm)	POIDS NET (Kg)	COLISAGE	
												CC BFR60 (m)	ECLISSE (NR)
MV51715	0.073	MV50736	400	75.7	4.5	26.6	8.889	82.8/60.9/44.5	MV50786	400	9.035	6	4
		MV50737	500				10.136	92.5/78.5/48.5	MV50787	500	10.282		
		MV50738	600	74.7	4.9	27.4	12.792	86.2/71.5/48.3	MV50788	600	12.938		

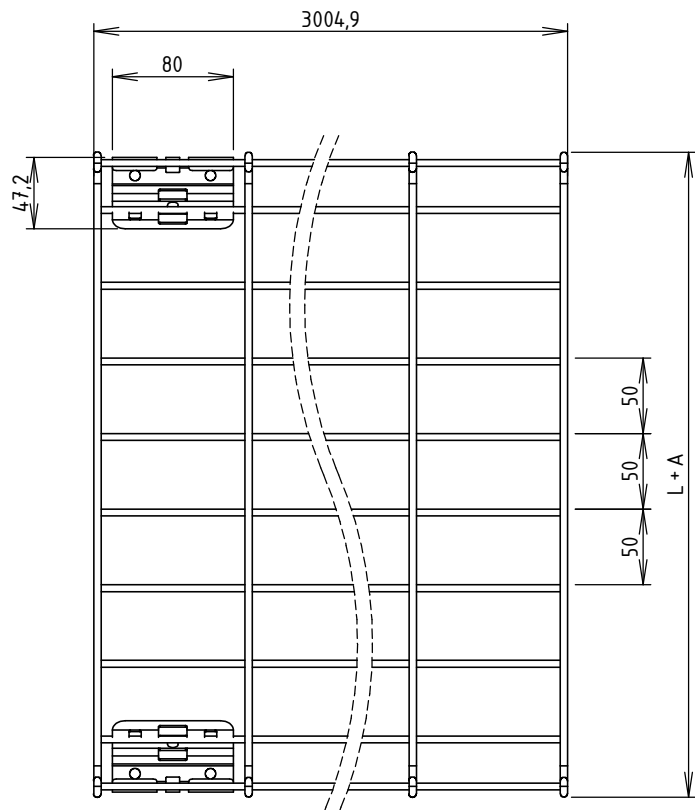

CC BFR60 HP
(MV50736 à MV50738)

ECLISSE AUTO BFR ECO Ø4.9 HP
(MV51715)

ECLISSE AUTO BFR ECO Ø4.9 HP:

Matière: BANDE REFENDUE 1.25 S350GD + ZA255

Revêtement: ZA255 - NF EN 10346

CC BFR60 HP:

Matière: FIL Ø4.5 C9D CRAPAL 4 - NF EN 10016-2

: FIL Ø4.9 C9D CRAPAL 4 - NF EN 10016-2

Revêtement: ZA280 CLASSE A - NF EN 10244-2

CPS (Charge Pratique de Sécurité selon NF EN 61537)

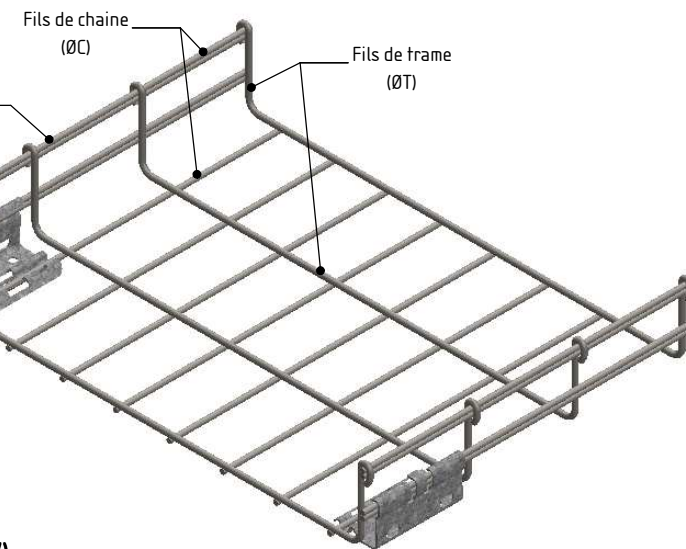

	DESIGNATION:		CC BFR60 PRE-ECLISSE HP	
	Usine de Liernais BP 1 21430 LIERNAIS TEL.: 03.80.90.51.00 FAX: 03.80.84.43.66	DESSINE PAR: BERGEROT D.	VERIFIE PAR: LEGUY C.	FORMAT A4 H
	DATE: 16/09/2016	ECHELLE: 1:5		
	N°:	MV50786 à MV50788_02		