

INERTIE
ECHELLE 1:1

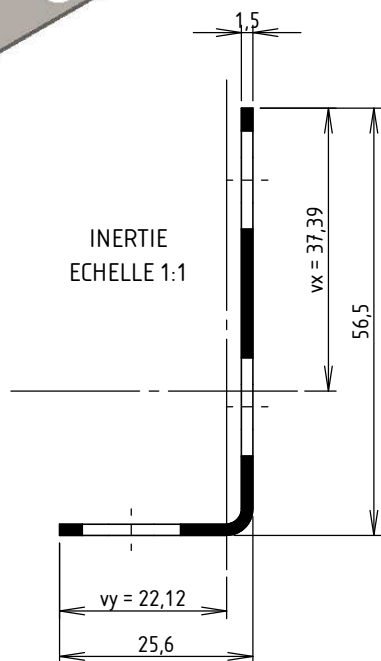

vx = 37.39 mm
 vy = 22.12 mm
 s = 60.6 mm²
 Ixx = 18793.46 mm⁴
 Iyy = 2359.12 mm⁴
 Ixx/vx = 502.69 mm³
 Iyy/vy = 106.67 mm³

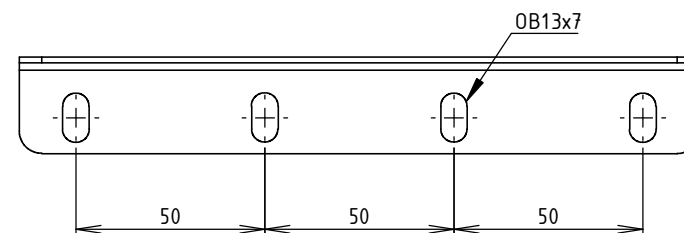
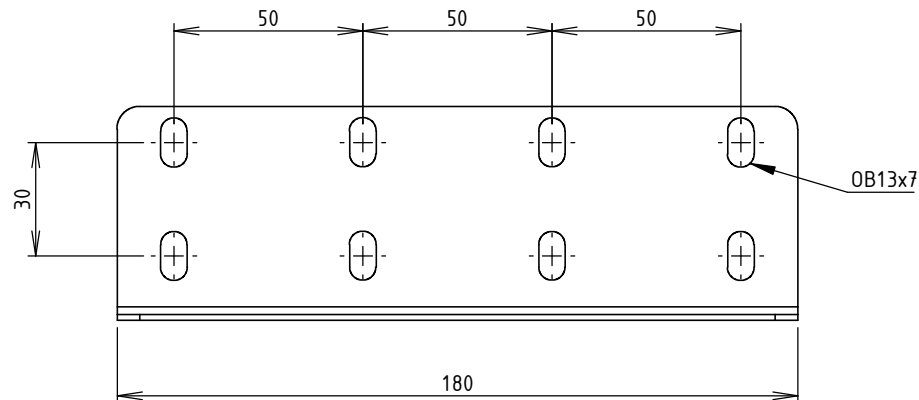

Poids net: 0.167 Kg
 Matière: BD REFENDUE 1,50 S235 JR
 Revêtement: GAC - Galvanisation à chaud par immersion selon NF EN 1461
 Dimensionnel garanti avant galvanisation
 Colisage: NR

 	DESIGNATION:			FORMAT A4 H
	ECLISSE A BOULONNER BRNHL65/80 LG180 GAC			
Usine de Liernais BP 1 21430 LIERNAIS TEL.: 03.80.90.51.00 FAX: 03.80.84.43.66	DESSINE PAR:	BERGEROT D.	VERIFIE PAR:	LEGUY C.
	DATE:	24/04/2019	ECHELLE:	1:2
	N°:	MVC0320JA_02		

