

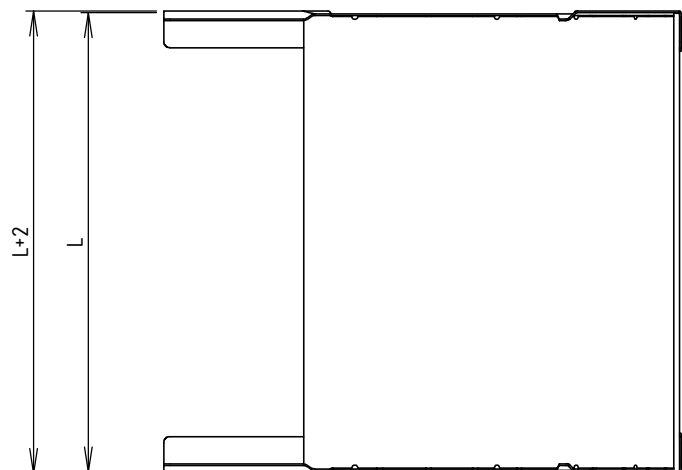

CODE	REF.	L (mm)	POIDS NET (Kg)
MVG1720LL	305	303.8	1,946
MVG1720LP	395	393.8	2,253
MVG1720LU	515	513.8	2,661
MVG1720LX	605	603.8	2,968

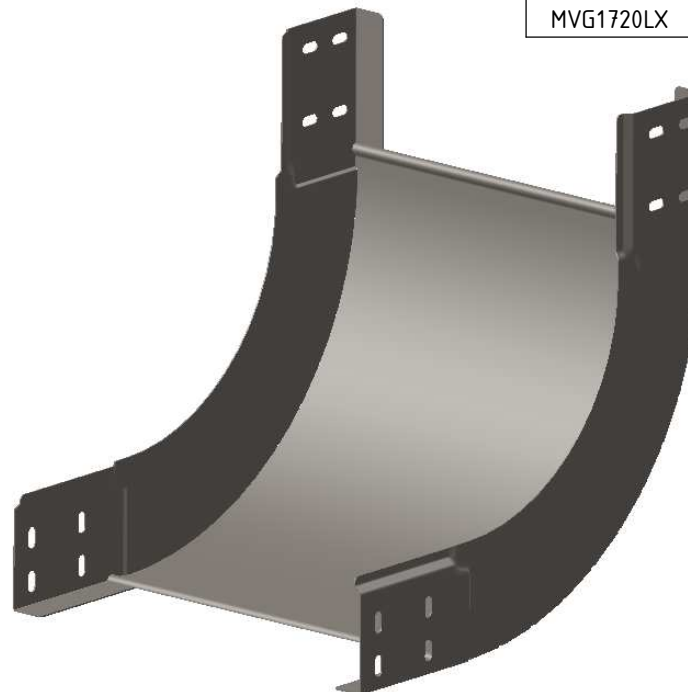
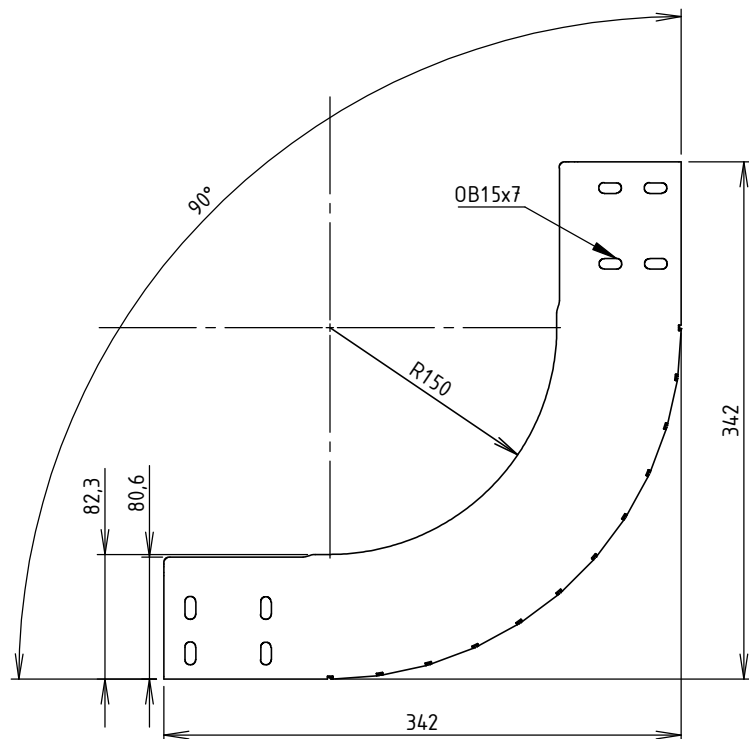

Colisage : 2 pièces
 Assemblage réalisé par clinchage
 Matière cornière: FEUILLE 1.00 DC01 - NF EN 10130/10131
 Matière fond: FEUILLE 1.00 DC01 - NF EN 10130/10131
 Revêtement: GAC - Galvanisation à chaud par immersion selon NF EN 1461
 Dimensionnel garanti avant galvanisation

  Usine de Liernais BP 1 21430 LIERNAIS TEL.: 03.80.90.51.00 FAX: 03.80.84.43.66	DESIGNATION:			FORMAT A4 H
	COUDE CONCAVE 90° BRN80 NP R150 GAC			
	DESSINE PAR: DOS SANTOS A.	VERIFIE PAR: LEGUY C.		
	DATE: 17/02/2020	ECHELLE: 1:5		
N°:	MVG1720LL à MVG1720LX_01		