

**ECLISSE AUTO BFR ECO  
Ø4.9 INOX 316L**

**CC BFR60 INOX 304L**

**CC BFR60 PRE-ECLISSE INOX 304L**

CODE	POIDS NET (Kg)	CODE	L (mm)	H (mm)	ØC (mm)	A (mm)	POIDS NET (Kg)	CPS portée 1.5/2.0/2.5 m (daN/m)	CODE	L (mm)	POIDS NET (Kg)	COLISAGE	
												CC BFR60 (m)	ECLISSE (NR)
MV51815	0.085	MV50636	400	75.7	4.5	26.6	8.678	82.8/60.9/44.5	MV50686	400	8.848	6	4
		MV50637	500				9.895		92.5/78.5/48.5	MV50687	500		
		MV50638	600	74.7	4.9	27.4	12.509	86.2/71.5/48.3	MV50688	600	12.679		

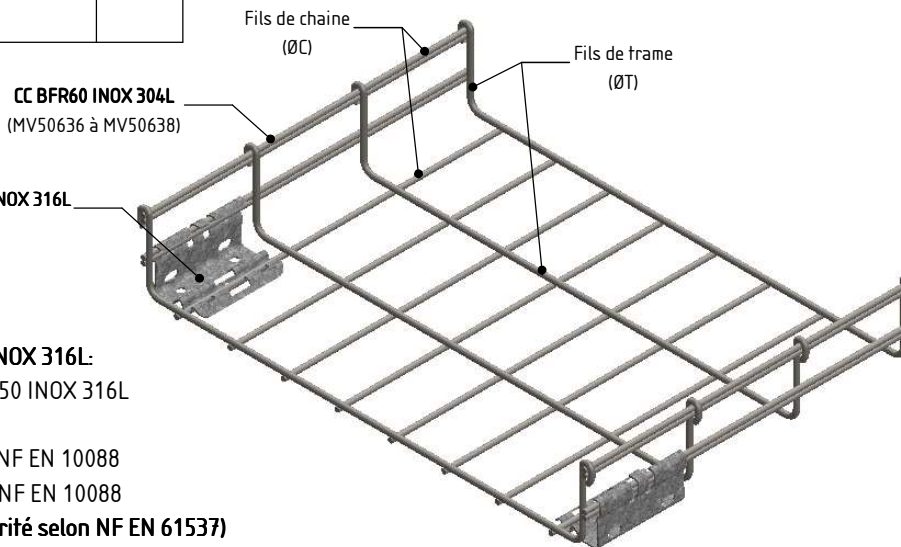
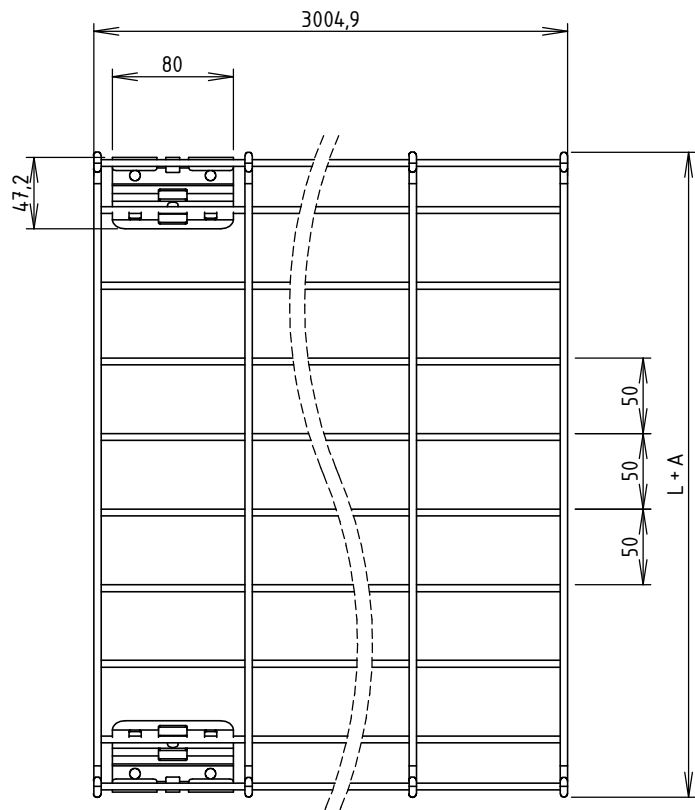

**ECLISSE AUTO BFR ECO Ø4.9 INOX 316L:**  
Matière: BANDE REFENDUE 1.50 INOX 316L

**CC BFR60 INOX 304L:**  
Matière: FIL Ø4.5 INOX 304L - NF EN 10088  
: FIL Ø4.9 INOX 304L - NF EN 10088

**CPS (Charge Pratique de Sécurité selon NF EN 61537)**

 Usine de Liernais BP 1 21430 LIERNAIS TEL.: 03.80.90.51.00 FAX: 03.80.84.43.66	DESIGNATION:		CC BFR60 PRE-ECLISSE INOX 304L	
	DESSINE PAR:	BERGEROT D.	VERIFIE PAR:	LEGUY C.
	DATE:	15/09/2016	ECHELLE:	1:5
	N°:	MV50686 à MV50688_02		
		FORMAT	A4 H	