

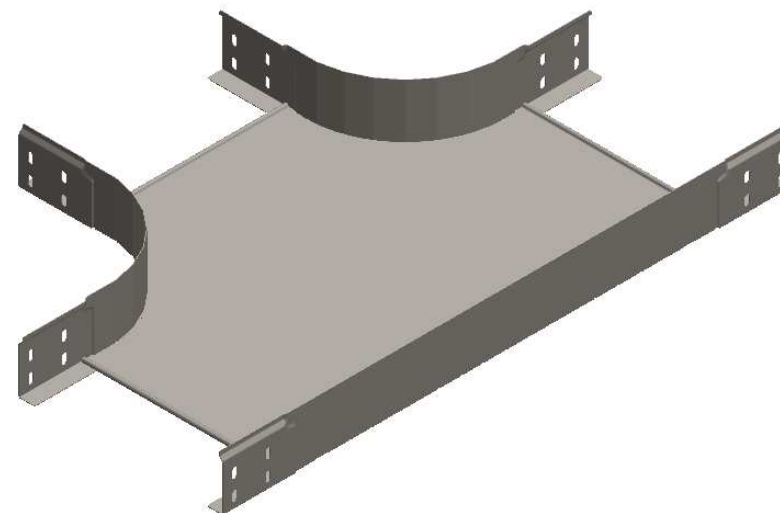

CODE	REF.	L (mm)	L1 (mm)	L2 (mm)	POIDS NET (Kg)	COLISAGE (NR)
MVG1520LL	305	851.4	303.8	578.4	3,773	4
MVG1520LP	395	941.4	393.8	668.4	4,806	2
MVG1520LU	515	1061.4	513.8	788.4	6,398	2
MVG1520LX	605	1151.4	603.8	878.4	7,746	2

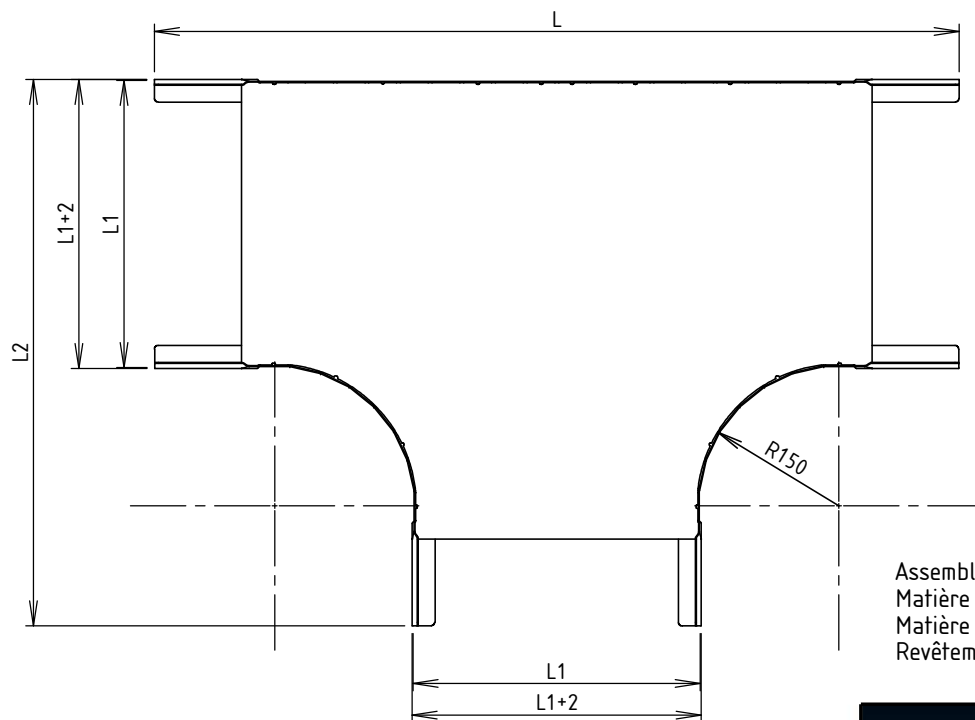
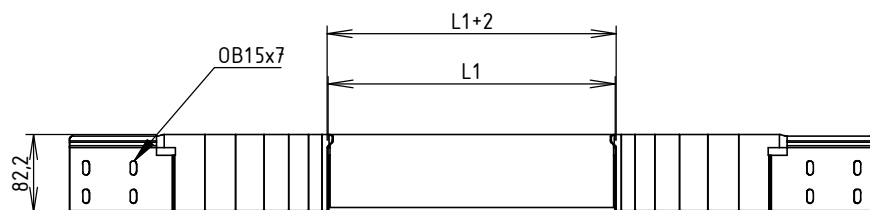

Assemblage réalisé par clinchage
 Matière cornière: BD REFENDUE 1,00 DC01 - NF EN 10130/10131
 Matière fond: FEUILLE 1,00 DC01 - NF EN 10130/10131
 Revêtement: GAC - Galvanisation à chaud par immersion selon NF EN 1461
 Dimensionnel garanti avant galvanisation

  Usine de Liernais BP 1 21430 LIERNAIS TEL.: 03.80.90.51.00 FAX: 03.80.84.43.66	DESIGNATION:		TE EGAL BRN80 NP R150 GAC		
	Propriété GEWISS France - Toute reproduction et utilisation tierce requièrent l'accord écrit de GEWISS France				
	DESSINE PAR:	DOS SANTOS A.	VERIFIE PAR:	LEGUY C.	FORMAT A4 H
	DATE:	17/02/2020	ECHELLE:	1:8	
N°:	MVG1520LL à MVG1520LX_01			