

ECLISSE AUTO BFR ECO Ø3.9 INOX 316L		CC BFR60 INOX 304L				CC BFR60 PRE-ECLISSE INOX 304L					
CODE	POIDS NET (Kg)	CODE	L (mm)	H (mm)	POIDS NET (Kg)	CPS portée 1.5/2.0/2.5 m (daN/m)	CODE	L (mm)	POIDS NET (Kg)	COLISAGE	
										CC BFR60 (m)	ECLISSE (NR)
MV51813	0.085	MV50630	50	75	1.837	15/10/7.5	MV50680	50	1.922	24	8
		MV50631	100		2.223	28/18/14	MV50681	100	2.393		16
		MV50632	150		2.610	32/25/16	MV50682	150	2.780	12	8
		MV50633	200		3.522		MV50683	200	3.692		

Chaque longueur de chemin de câbles est livrée avec 2 éclisses.
Sauf pour la largeur 50, livrée avec 1 seule éclisse (voir colisage)

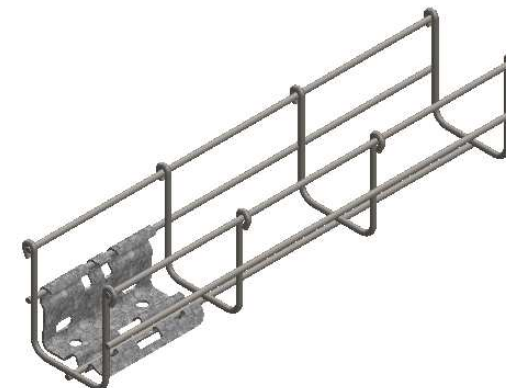
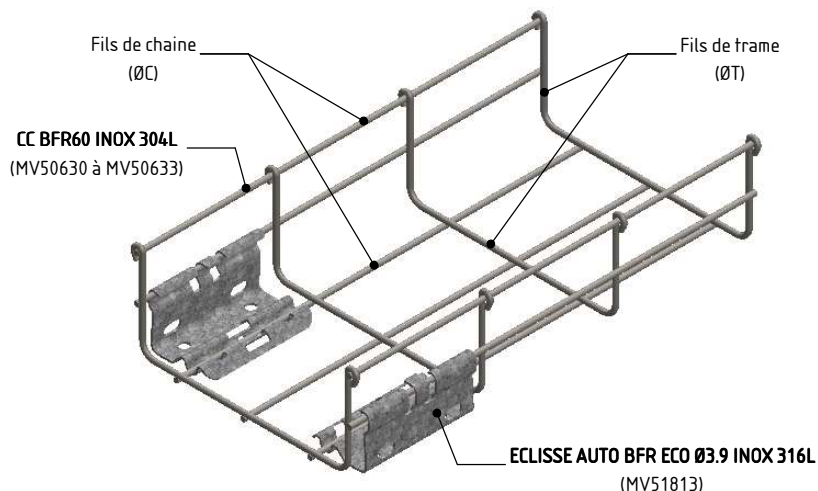

ECLISSE AUTO BFR ECO Ø3.9 INOX 316L:

Matière: BANDE REFENDUE 1.50 INOX 316L

CC BFR60 INOX 304L:

Matière: FIL Ø3.7 INOX 304L - NF EN 10088

CPS (Charge Pratique de Sécurité selon NF EN 61537)

	DESIGNATION:				CC BFR60 PRE-ECLISSE INOX 304L	
	Usine de Liernais BP 1 21430 LIERNAIS TEL.: 03.80.90.51.00 FAX: 03.80.84.43.66	DESSINE PAR:	BERGEROT D.	VERIFIE PAR:	LEGUY C.	FORMAT A4 H
		DATE:	15/09/2016	ECHELLE:	1:4	
		N°:	MV50680 à MV50683_02			