

ECLISSE AUTO BFR ECO Ø4.5 INOX 316L

CC BFR30 INOX 304L

CC BFR30 PRE-ECLISSE INOX 304L

CODE	POIDS NET (Kg)	CODE	L (mm)	H (mm)	ØC (mm)	A (mm)	POIDS NET (Kg)	CPS portée 1.5/2.0/2.5 m (daN/m)	CODE	L (mm)	POIDS NET (Kg)	COLISAGE	
												CC BFR30 (m)	ECLISSE (NR)
MV51814	0.085	MV50624	250	42.4	3.7	23.4	3.683	??/??	MV50674	250	3.853	6	4
		MV50625	300	42.6	4.5	25	5.337	28.1/17.9/11.8					

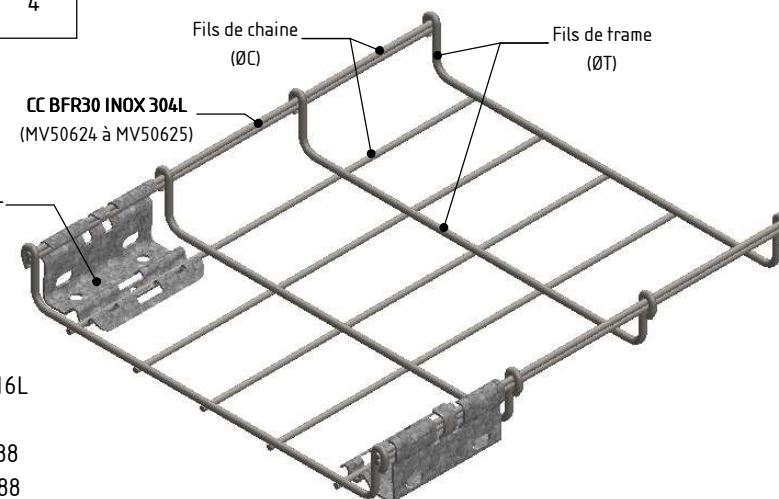
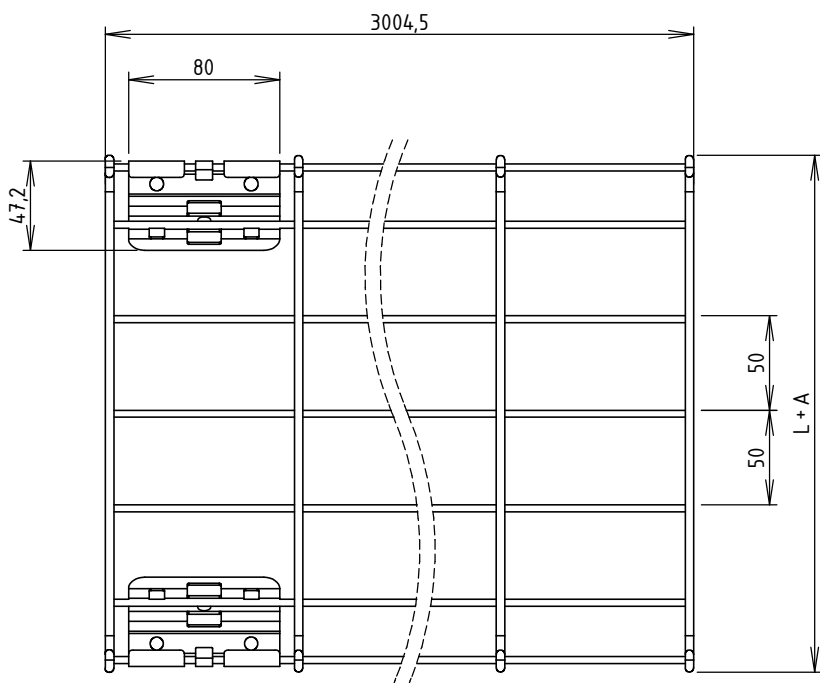

ECLISSE AUTO BFR ECO Ø4.5 INOX 316L (MV51814)

ECLISSE AUTO BFR ECO Ø4.5 INOX 316L:

Matière: BANDE REFENDUE 1.50 INOX 316L

CC BFR30 INOX 304L:

Matière: FIL Ø3.7 INOX 304L - NF EN 10088

: FIL Ø4.5 INOX 304L - NF EN 10088

CPS (Charge Pratique de Sécurité selon NF EN 61537)

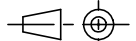
 Usine de Liernais BP 1 21430 LIERNAIS TEL.: 03.80.90.51.00 FAX: 03.80.84.43.66	DESIGNATION:		CC BFR30 PRE-ECLISSE INOX 304L	
	DESSINE PAR:	BERGEROT D.	VERIFIE PAR:	LEGUY C.
	DATE:	15/09/2016	ECHELLE:	1:4
	N°:	MV50674 à MV50675		

FORMAT A4 H