



Colisage: 6 m
 Poids net: 6.863 Kg
 Matière: FIL CLAIR Ø4.5 C9D - NF EN 16120-2
 FIL CLAIR Ø4.9 C9D - NF EN 16120-2
 Revêtement: EZ: Fe/Zn/A - NF EN ISO 2081
 Couche moyenne de revêtement: 10 µm (1 µm = 7.2 g/m²)
 CPS: Charge pratique de sécurité - NF EN 61537
 33 daN/m : portée 1.5m
 22 daN/m : portée 2.0m
 15 daN/m : portée 2.5m

 	DESIGNATION:		CC 400 BFR30 EZ		
	Propriété GEWISS France - Toute reproduction et utilisation tierce requièrent l'accord écrit de GEWISS France				
Usine de Liernais BP 1 21430 LIERNAIS TEL.: 03.80.90.51.00 FAX: 03.80.84.43.66	DESSINE PAR:	BERGEROT D.	VERIFIE PAR:	LEGUY C.	FORMAT A4 H
	DATE:	09/07/2020	ECHELLE:	1:5	
	N°:	MV50426_03			

CODE	REF.	POIDS NET (Kg)	POIDS NET (Kg/m)	vx (mm)	vy (mm)	S (mm ²)	Ixx (mm ⁴)	Iyy (mm ⁴)	Ixx/vx (mm ³)	Iyy/vy (mm ³)	RAYON DE GIRATION R (mm)
MV50426	400 BFR30	6.863	2.287	24.535	208.4	190.852	37106.81	4176650.576	1512.4	20041.51	209.601

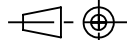
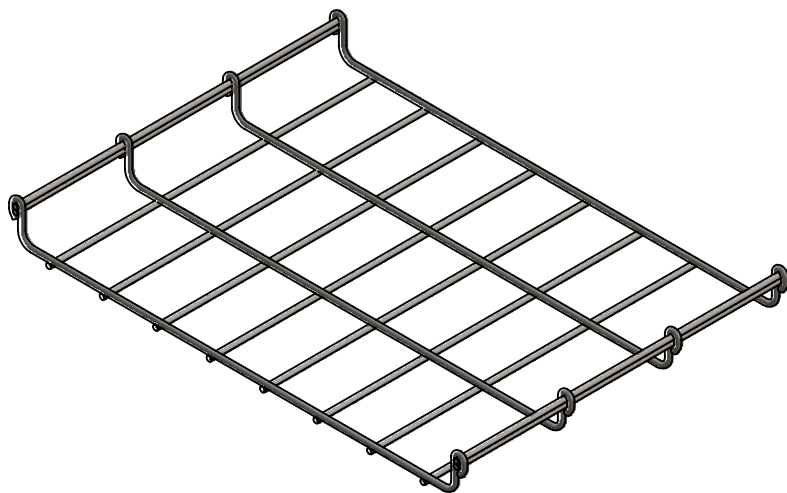
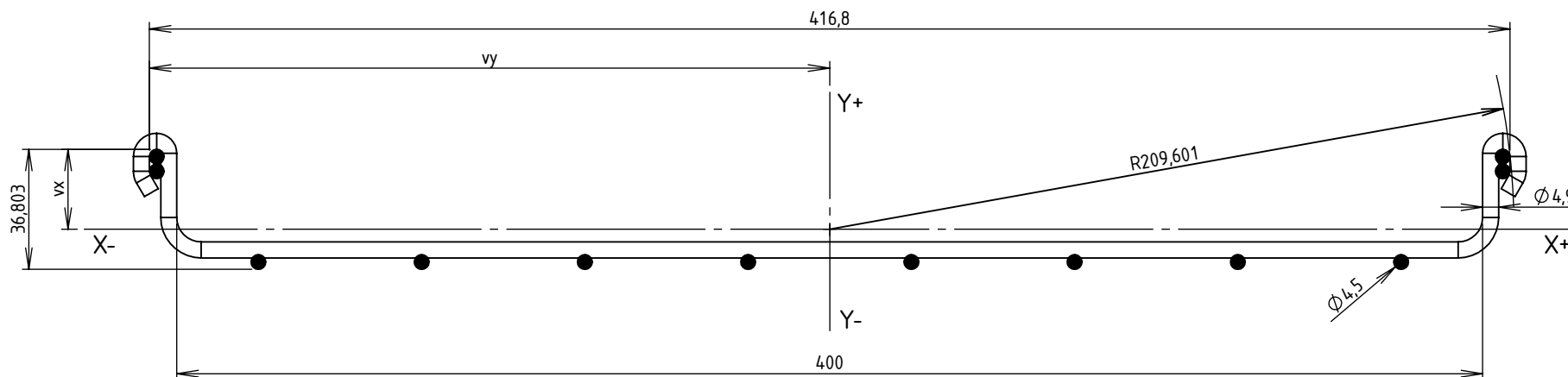

Matière: FIL CLAIR Ø4.5 C9D - NF EN 16120-2
 FIL CLAIR Ø4.9 C9D - NF EN 16120-2
 Revêtement: EZ: Fe/Zn/A - NF EN ISO 2081
 Couche moyenne de revêtement: 10 µm (1 µm = 7.2 g/m²)



Usine de Liernais
 BP 1
 21430 LIERNAIS
 TEL.: 03.80.90.51.00
 FAX: 03.80.84.43.66

DESIGNATION: CC 400 BFR30 EZ INERTIE
 Propriété GEWISS France - Toute reproduction et utilisation tierce requièrent l'accord écrit de GEWISS France

DESSINE PAR:	BERGEROT D.	VERIFIE PAR:	LEGUY C.	FORMAT A4 H
DATE:	09/07/2020	ECHELLE:	1:2	
N°:	MV50426_03			

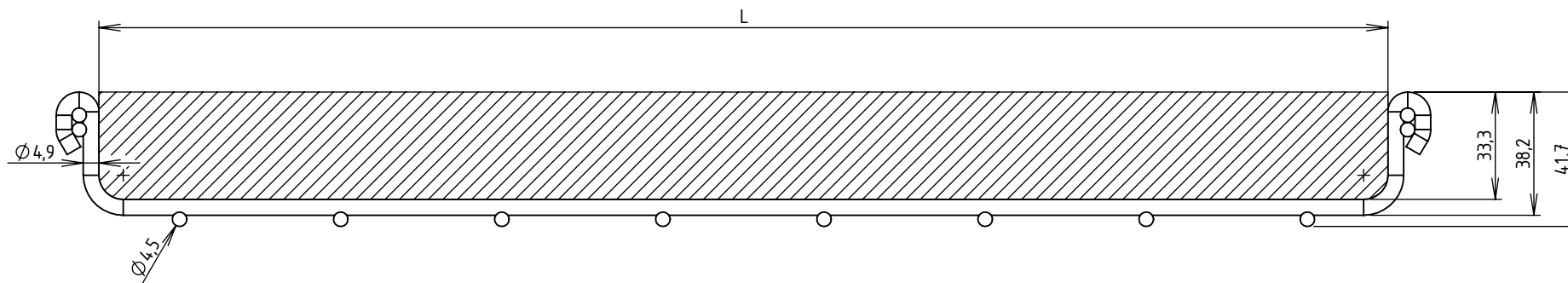

CODE	L (mm)	SECTION UTILE (mm ²)	CONTENANCE (Kg/m)	
			Communication (d = 0.15 Kg/cm ² /m)	Puissance (d = 0.25 Kg/cm ² /m)
MV50X26	400	13297	19.95	33.24



Usine de Liernais
BP 1
21430 LIERNAIS
TEL.: 03.80.90.51.00
FAX: 03.80.84.43.66

DESIGNATION:
SECTIONS UTILES ET CONTENANCES BFR30
CC 400 BFR30

Propriété GEWISS France - Toute reproduction et utilisation tierce requièrent l'accord écrit de GEWISS France

DESSINE PAR:	BERGEROT D.	VERIFIE PAR:	LEGUY C.	FORMAT A4 H
DATE:	05/06/2024	ECHELLE:	1:2	
N°:	MV50X26			