

ECLISSE AUTO BFR ECO Ø3.9 INOX 316L		CC BFR60 INOX 316L				CC BFR60 PRE-ECLISSE INOX 316L					
CODE	POIDS NET (Kg)	CODE	L (mm)	H (mm)	POIDS NET (Kg)	CPS portée 1.5/2.0/2.5 m (daN/m)	CODE	L (mm)	POIDS NET (Kg)	COLISAGE	
										CC BFR60 (m)	ECLISSE (NR)
MV51813	0.085	MV50830	50	75	1.860	15/10/7.5	MV50880	50	1.945	24	8
		MV50831	100		2.252	28/18/14	MV50881	100	2.422		16
		MV50832	150		2.643		MV50882	150	2.813	12	8
		MV50833	200		3.566	32/25/16	MV50883	200	3.736		

Chaque longueur de chemin de câbles est livrée avec 2 éclisses.
Sauf pour la largeur 50, livrée avec 1 seule éclisse (voir colisage)

ECLISSE AUTO BFR ECO Ø3.9 INOX 316L:

Matière: BANDE REFENDUE 1.50 INOX 316L

CC BFR60 INOX 316L:

Matière: FIL Ø3.7 INOX 316L - NF EN 10088

CPS (Charge Pratique de Sécurité selon NF EN 61537)

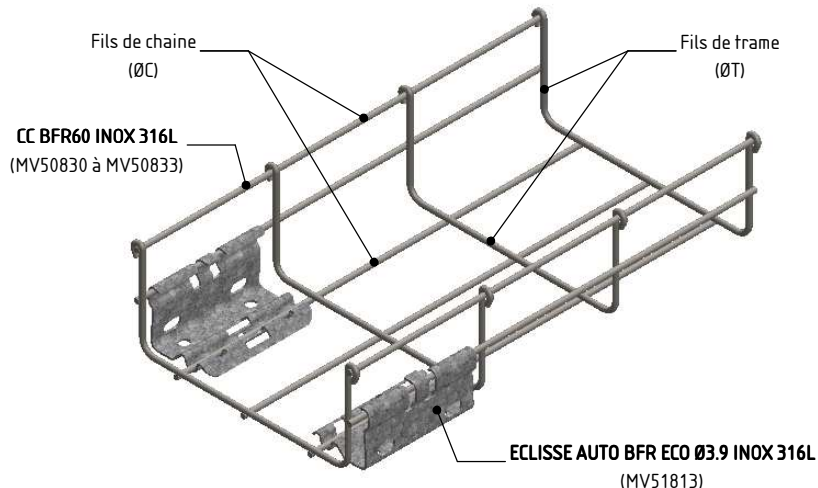
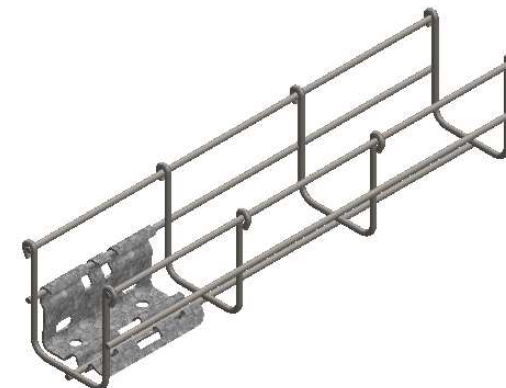

	DESIGNATION:			
	CC BFR60 PRE-ECLISSE INOX 316L			
Usine de Liernais BP 1 21430 LIERNAIS TEL.: 03.80.90.51.00 FAX: 03.80.84.43.66	DESSINE PAR:	BERGEROT D.	VERIFIE PAR:	LEGUY C.
	DATE:	16/09/2016	ECHELLE:	1:4
N°:	MV50880 à MV50883_02			

FORMAT A4 H