

Matière : BANDE REFENDUE 2.00 S235 JR + GAC - NF EN ISO 10051/1461  
 Revêtement: GAC - NF EN 1461

CODE	REF	L (mm)	SURFACE (mm <sup>2</sup> )	POIDS NET (kg)	COLISAGE (NR)	CPS (daN)
MV60214	LG510	513	152897	1.194	8	130
MV60215	LG610	613	167223	1.306	6	100

**GEWISS**

**MAVIL**

Usine de Liernais  
 BP 1  
 21430 LIERNAIS  
 TEL.: 03.80.90.51.00  
 FAX: 03.80.84.43.66

DESIGNATION:

CONSOLE OMEGA RENF Z275

Propriété GEWISS France - Toute reproduction et utilisation tierce requièrent l'accord écrit de GEWISS France

DESSINE PAR: DOS SANTOS A.	VERIFIE PAR: LEGUY C.	FORMAT A4 H
DATE: 05/03/2020	ECHELLE: 1:5	
N°: MV60214 à MV60215		

CODE	REF	POIDS NET (kg)	COLISAGE (NR)	CPS (daN)	vx (mm)	vy (mm)	S (mm <sup>2</sup> )	Ixx (mm <sup>4</sup> )	Iyy (mm <sup>4</sup> )	Ivx/vx (mm <sup>3</sup> )	Iyy/vy (mm <sup>3</sup> )
MV60214	LG510	1.194	8	130	7.655	29.15	128.14	3884.73	42482.54	507.46	1457.37
MV60215	LG610	1.306	6	100							

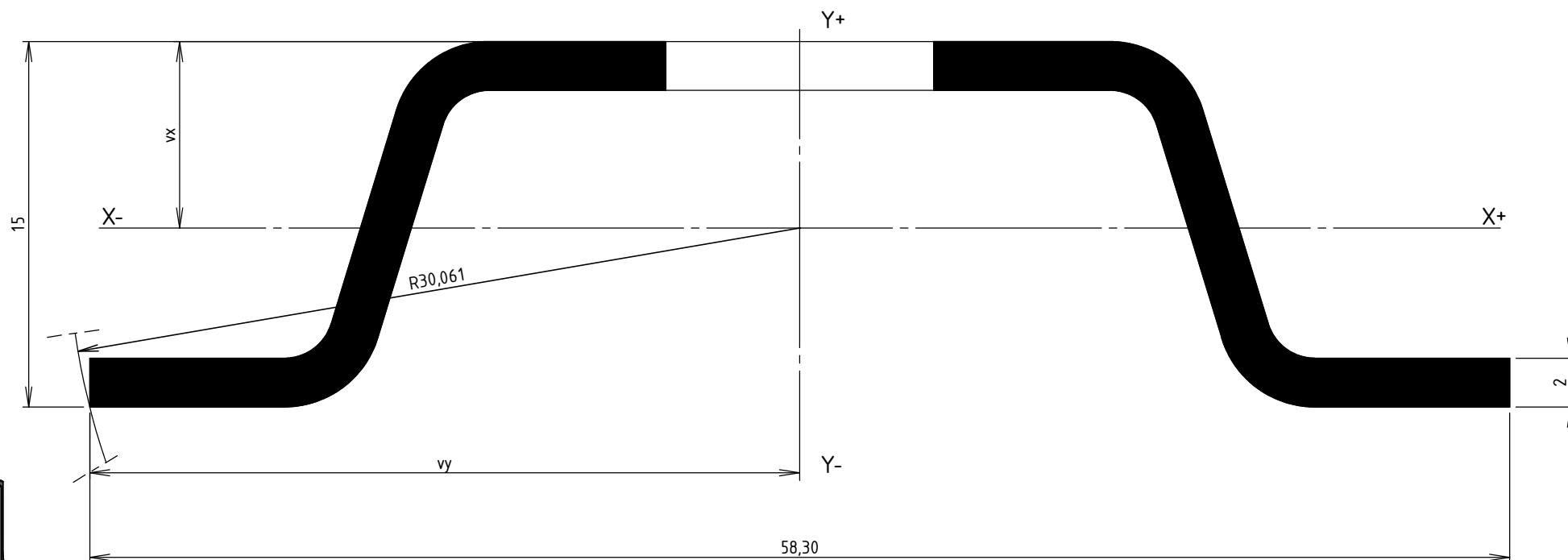

Revêtement: GAC - NF EN 1461

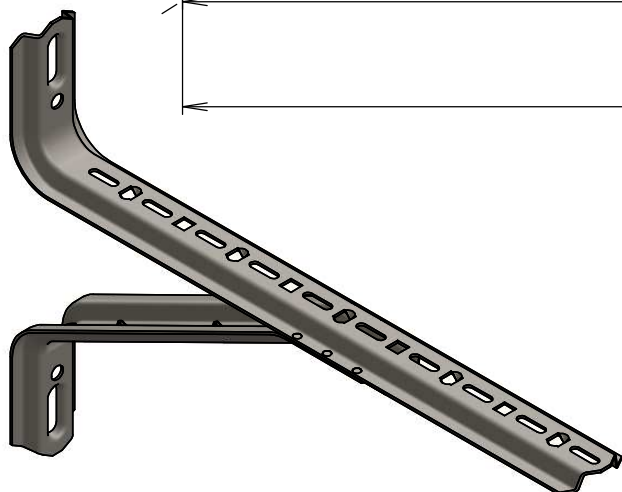

 <b>MAVIL</b>	DESIGNATION:			CONSOLE OMEGA RENF GAC INERTIES	
	Propriété GEWISS France - Toute reproduction et utilisation tierce requièrent l'accord écrit de GEWISS France				
Usine de Liernais BP 1 21430 LIERNAIS TEL.: 03.80.90.51.00 FAX: 03.80.84.43.66	DESSINE PAR:	DOS SANTOS A.	VERIFIE PAR:	LEGUY C.	FORMAT A4 H
	DATE:	09/03/2020	ECHELLE:	4:1	
	N°:	MV60214 à MV60215			