

ECLISSE AUTO BFR ECO Ø3.9 Z275		CC BFR60 EZ				CC BFR60 PRE-ECLISSE EZ					
CODE	POIDS NET (Kg)	CODE	L (mm)	H (mm)	POIDS NET (Kg)	CPS portée 1.5/2.0/2.5 m (daN/m)	CODE	L (mm)	POIDS NET (Kg)	COLISAGE	
										CC BFR60 (m)	ECLISSE (NR)
MV51113	0.085	MV50430	50	75	1.843	15/10/7.5	MV50480	50	1.928	24	8
		MV50431	100		2.231	28/18/14	MV50481	100	2.401		16
		MV50432	150		2.619		32/25/16	MV50482	150	2.789	12
		MV50433	200		3.534	MV50483		200	3.704		

Chaque longueur de chemin de câbles est livrée avec 2 éclisses.
Sauf pour la largeur 50, livrée avec 1 seule éclisse (voir colisage)

ECLISSE AUTO BFR ECO Ø3.9 Z275:

Matière: BANDE REFENDUE 1.50 S350GD + Z275

Revêtement: Z275 - NF EN 10346

CC BFR60 EZ:



Matière: FIL CLAIR Ø3.7 C9D - NF EN 16120-2

Revêtement: EZ: Fe/Zn/A - NF EN ISO 2081

Couche moyenne de revêtement: 10 µm (1 µm = 7.2 g/m²)

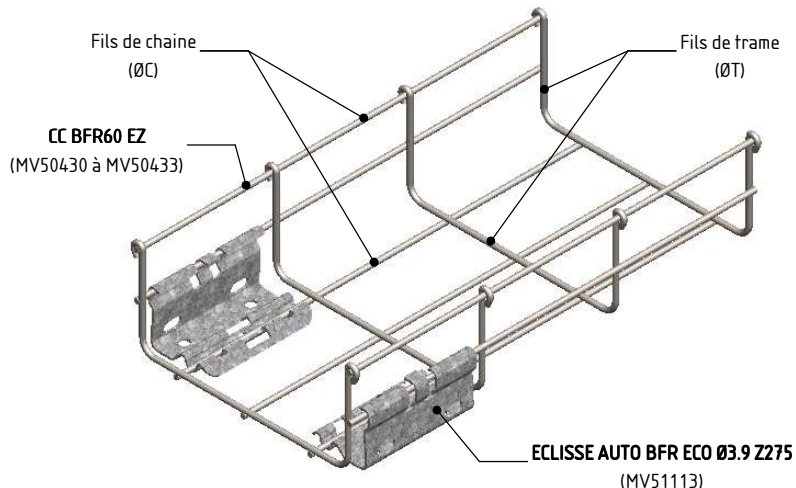
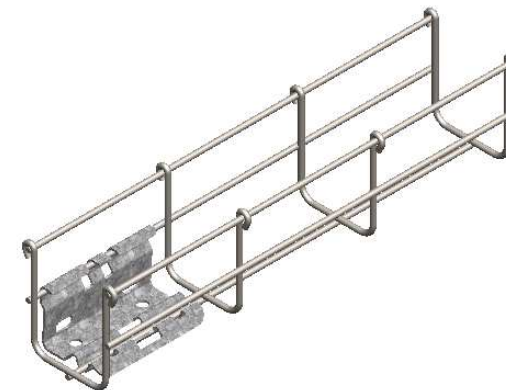
CPS (Charge Pratique de Sécurité selon NF EN 61537)



 	DESIGNATION: CC BFR60 PRE-ECLISSE EZ			
	Propriété GEWISS France - Toute reproduction et utilisation tierce requièrent l'accord écrit de GEWISS France			
Usine de Liernais BP 1 21430 LIERNAIS TEL.: 03.80.90.51.00 FAX: 03.80.84.43.66	DESSINE PAR: BERGEROT D.	VERIFIE PAR: LEGUY C.	FORMAT A4 H	
	DATE: 31/10/2019	ECHELLE: 1:4		
N°:	MV50480 à MV50483_03			