

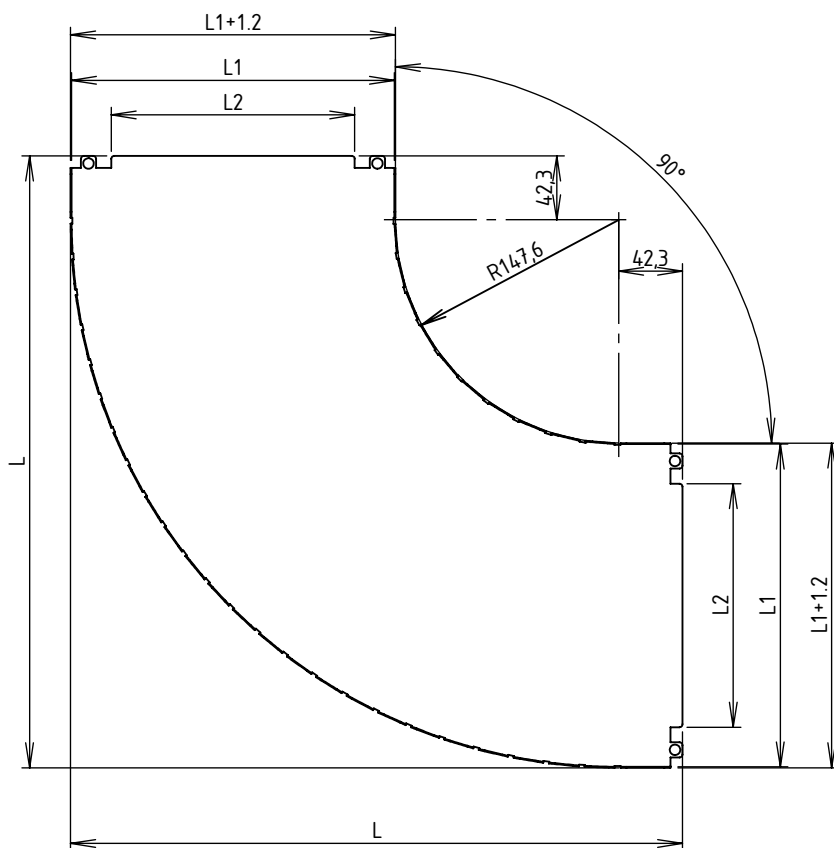

CODE	REF.	L (mm)	L1 (mm)	L2 (mm)	POIDS NET (Kg)	COLISAGE (NR)
MVC1110AC	65	254.6	63.5	11	0.139	10
MVC1110AD	95	284.6	93.5	41	0.206	10
MVC1110AF	155	344.6	153.5	101	0.362	10
MVC1110AH	215	404.6	213.5	161	0.547	10
MVC1110AL	305	494.6	303.5	251	0.876	10
MVC1110AP	395	584.6	393.5	341	1.270	10
MVC1110AU	515	704.6	513.5	461	1.892	10
MVC1110AX	605	794.6	603.5	551	2.434	8



Matière : FEUILLE 0.60 2000x1500 S220GD + Z275 - NF EN 10143/10346
 Revêtement : Z275 - NF EN 10346

 	DESIGNATION:		CO COUDE 90° BRN R150 Z275		
	Propriété GEWISS France - Toute reproduction et utilisation tierce requièrent l'accord écrit de GEWISS France				
Usine de Liernais BP 1 21430 LIERNAIS TEL.: 03.80.90.51.00 FAX: 03.80.84.43.66	DESSINE PAR:	NOUAILLES-LADERACH C.	VERIFIE PAR:	LEGUY C.	FORMAT A4 H
	DATE:	20/10/2025	ECHELLE:	1:5	
	N°:	MVC1110AC à MVC1110AX_01			