

CODE	REF.	L (mm)	L1 (mm)	L2 (mm)	COLISAGE (NR)	POIDS NET (Kg)
MVN1210LL	305	438.3	303.8	536.3	10	1,447
MVN1210LP	395	528.3	393.8	600	8	1,797
MVN1210LU	515	648.3	513.8	684.8	6	2,341
MVN1210LX	605	738.3	603.8	748.4	4	2,801

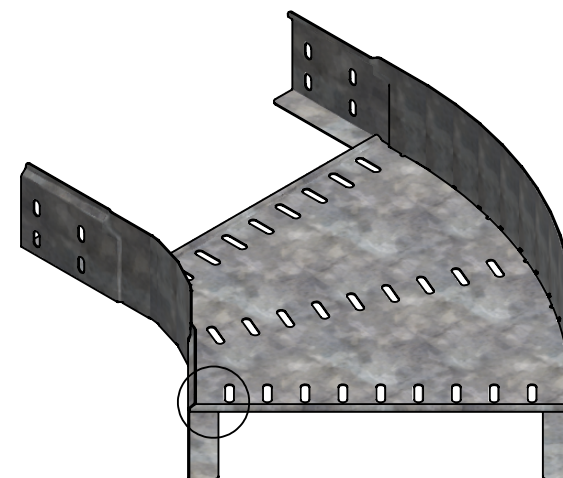

Assemblage réalisé par clinchage
 Matière cornière : BD REFENDUE 1 DX51D + Z275 - NF EN 10143/10346
 Matière de fond : FEUILLE 0.90 DX51D + Z275 - NF EN 10143/10346
 Revêtement : Z275 - NF EN 10346



Usine de Liernais
 BP 1
 21430 LIERNAIS
 TEL.: 03.80.90.51.00
 FAX: 03.80.84.43.66

DESIGNATION:

COUDE 135° BRX/BRN80 R150 Z275

Propriété GEWISS France - Toute reproduction et utilisation tierce requièrent l'accord écrit de GEWISS France

DESSINE PAR:	DOS SANTOS A.	VERIFIE PAR:	LEGUY C.	FORMAT A4 H
DATE:	10/02/2020	ECHELLE:	1:6	
N°:	MVN1210LL à MVN1210LX_01			