

Matière: BANDE REFENDUE 2.00 S250GD + Z275 - NF EN 10143/10346
 Revêtement: Z275 - NF EN 10346
 CPS (Charge Pratique de Sécurité) - NF EN 61537

CODE	REF.	L (mm)	POIDS NET (Kg)	COLISAGE (pièces)	CPS (daN)
MV60100	LG110	113	0.226	50	50
MV60101	LG210	213	0.334		
MV60102	LG310	313	0.442	40	30



Usine de Liernais
 BP 1
 21430 LIERNAIS
 TEL.: 03.80.90.51.00
 FAX: 03.80.84.43.66

DESIGNATION:

CONSOLE OMEGA Z275

Propriété GEWISS France - Toute reproduction et utilisation tierce requièrent l'accord écrit de GEWISS France

DESSINE PAR:	BERGEROT D.	VERIFIE PAR:	LEGUY C.	FORMAT A4 H
DATE:	08/01/2021	ECHELLE:	1:3	
N°:	MV60100 à MV60102_01			

CODE	REF	POIDS NET (kg)	vx (mm)	vy (mm)	S (mm ²)	Ixx (mm ⁴)	Iyy (mm ⁴)	Ixx/vx (mm ³)	Iyy/vy (mm ³)	RAYON DE GIRATION (mm)
MV60100	LG110	0.226	7.655	29.15	128.14	3884.73	42482.54	507.48	1457.38	30.06
MV60101	LG210	0.334								
MV60102	LG310	0.446								

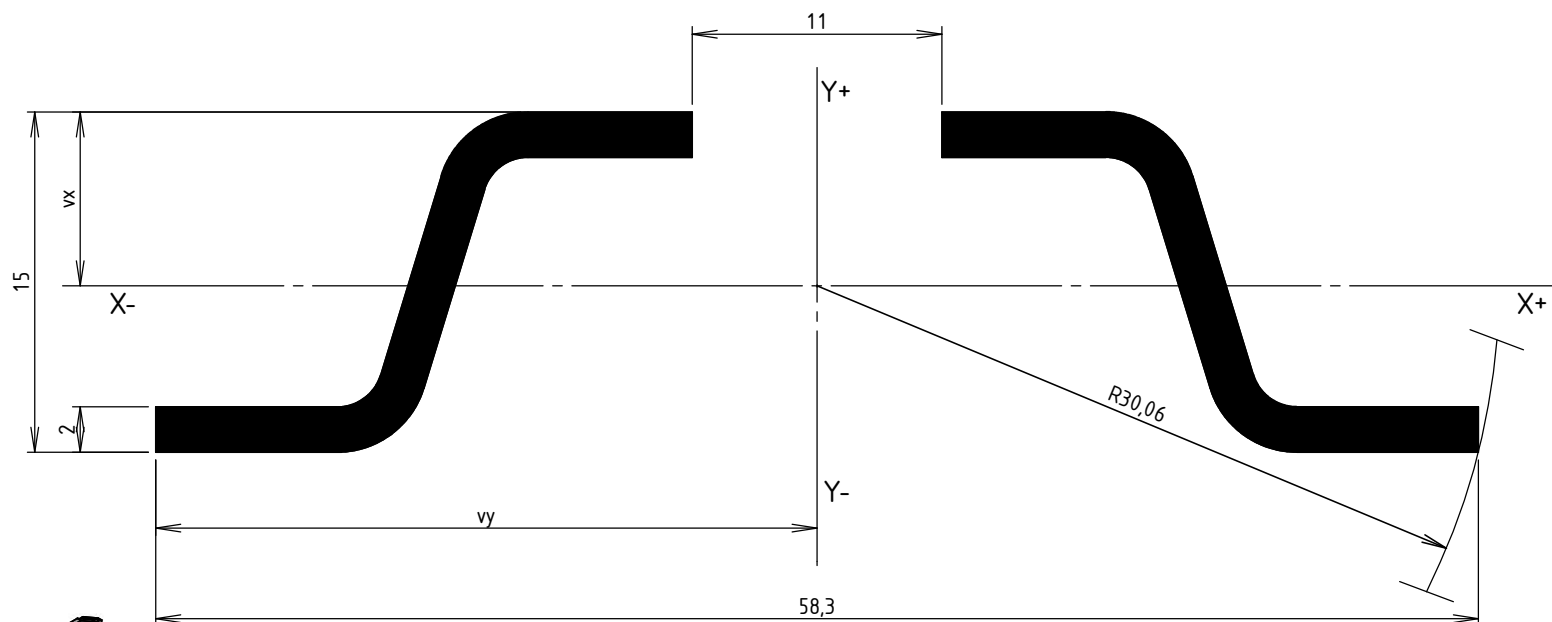

Matière: BANDE REFENDUE 2.00 S250GD + Z275 - NF EN 10143/10346



Usine de Liernais
BP 1
21430 LIERNAIS
TEL.: 03.80.90.51.00
FAX: 03.80.84.43.66

DESIGNATION:

CONSOLE OMEGA Z275
INERTIES

Propriété GEWISS France - Toute reproduction et utilisation tierce requièrent l'accord écrit de GEWISS France

DESSINE PAR:	BERGEROT D.	VERIFIE PAR:	LEGUY C.	FORMAT A4 H
DATE:	08/01/2021	ECHELLE:	3:1	
N°:	MV60100 à MV60102_01			